

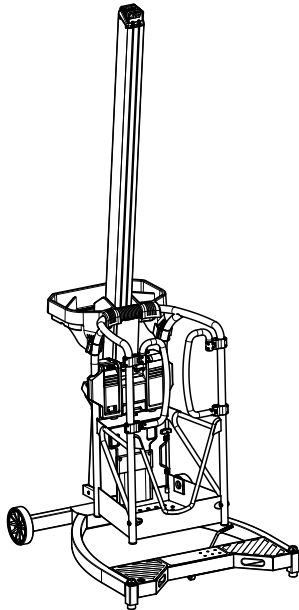

Operation, Safety, Service and Maintenance Manual

Keep this manual with the machine at all times.



LiftPod Model FS80

CE - English

This page intentionally left blank.

FOREWORD

Original Instructions. Keep this manual with the machine at all times.

The purpose of this manual is to provide owners, users, operators, lessors, and lessees with the precautions and operating procedures essential for the safe and proper machine operation for its intended purpose.

Due to continuous product improvements, JLG Industries, Inc. (JLG) reserves the right to make specification changes without prior notification. Contact JLG for updated information.

SAFETY ALERT SYMBOLS AND SAFETY SIGNAL WORDS



This is the Safety Alert Symbol. It is used to alert you to the potential personal injury hazards. Obey all safety messages that follow this symbol to avoid possible injury or death

⚠ DANGER

INDICATES AN IMMINENTLY HAZARDOUS SITUATION. IF NOT AVOIDED, WILL RESULT IN SERIOUS INJURY OR DEATH. THIS DECAL WILL HAVE A RED BACKGROUND.

⚠ WARNING

INDICATES A POTENTIALITY HAZARDOUS SITUATION. IF NOT AVOIDED, COULD RESULT IN SERIOUS INJURY OR DEATH. THIS DECAL WILL HAVE AN ORANGE BACKGROUND.

⚠ CAUTION

INDICATES A POTENTIALITY HAZARDOUS SITUATION. IF NOT AVOIDED, MAY RESULT IN MINOR OR MODERATE INJURY. IT MAY ALSO ALERT AGAINST UNSAFE PRACTICES. THIS DECAL WILL HAVE A YELLOW BACKGROUND.

⚠ WARNING

THIS PRODUCT MUST COMPLY WITH ALL SAFETY RELATED BULLETINS. CONTACT JLG OR THE LOCAL AUTHORIZED JLG REPRESENTATIVE FOR INFORMATION REGARDING SAFETY RELATED BULLETINS WHICH MAY HAVE BEEN ISSUED FOR THIS PRODUCT.

NOTICE

JLG MUST BE NOTIFIED IMMEDIATELY IN ALL INSTANCES WHERE JLG PRODUCTS HAVE BEEN INVOLVED IN AN ACCIDENT INVOLVING BODILY INJURY OR DEATH OF PERSONNEL OR WHEN SUBSTANTIAL DAMAGE HAS OCCURRED TO PERSONAL PROPERTY OR THE JLG PRODUCT.

NOTICE

JLG INDUSTRIES INC. SENDS SAFETY RELATED BULLETINS TO THE OWNER OF RECORDS OF THIS MACHINE. CONTACT JLG INDUSTRIES INC. TO INSURE THAT THE OWNER RECORDS ARE UPDATED AND ACCURATE.

For:

- Accident reporting
- Product safety publications
- Current owner updates
- Questions regarding product safety
- Standards and regulations compliance information
- Questions regarding special product applications
- Questions regarding product modifications

Contact:

Product Safety and Reliability Department
JLG Industries, Inc.
13244 Fountainhead Plaza
Hagerstown, MD 21742
USA

In USA:
Toll Free: 877-JLG-SAFE (877-554-7233)

Outside USA:
Phone: 717-485-6591
E-mail: ProductSafety@JLG.com

or your local JLG office
(see addresses on manual's rear cover)

FOREWORD

REVISION LOG

Original Issue of Manual 24 July 2009
Revised 14 August 2009
Revised 28 August 2009
Revised 18 December 2009

TABLE OF CONTENTS

SECTION - PARAGRAPH, SUBJECT	PAGE	SECTION - PARAGRAPH, SUBJECT	PAGE
SECTION - 1 - SAFETY PRECAUTIONS			
1.1 GENERAL	1-1	2.4 FUNCTION CHECK	2-10
1.2 PRE-OPERATION	1-2	Function Check Items	2-10
Operator Training and Knowledge	1-2	SECTION - 3 - MACHINE OPERATION	
Workplace Inspection	1-2	3.1 GENERAL	3-1
Machine Inspection	1-2	3.2 MACHINE DESCRIPTION	3-1
1.3 OPERATION	1-3	Detailed Description	3-2
General	1-3	Platform Configuration	3-3
Trip and Fall Hazard	1-4	Mast/Carriage Components	3-3
Electrocution Hazard	1-5	3.3 MACHINE OPERATION	3-4
Tipping Hazards	1-6	General	3-4
Crushing and Collision Hazards	1-7	Getting Started	3-4
1.4 MOVING, LIFTING AND REPOSITIONING	1-8	Assembly of the Machine	3-4
General	1-8	Disassembly of the Machine	3-9
Additional Safety Information	1-8	3.4 POWERPACK (OPTIONAL EQUIPMENT)	3-10
SECTION - 2 - PREPARATION AND INSPECTION		Battery Charging Operation	3-10
2.1 PERSONNEL REQUIREMENTS	2-1	Battery Charge Status Lights	3-10
Operator Requirements	2-1	Charging the Batteries Using the Fast Charge	
Operator Responsibility	2-1	Station	3-11
2.2 PREPARATION, INSPECTION, AND		Fast Charge Indicator Light Guide	3-12
MAINTENANCE	2-2	3.5 OPERATION	3-12
Pre-Start Inspection	2-4	Cordless Drill	3-12
2.3 DAILY WALK-AROUND INSPECTION	2-4	Powerpack Control Console (Optional	
Walk-Around Inspection Components	2-5	Equipment)	3-13
Tool Tray Pre-Start Inspection	2-9	Elevating	3-14
		Descending	3-16

TABLE OF CONTENTS

SECTION - PARAGRAPH, SUBJECT	PAGE	SECTION - PARAGRAPH, SUBJECT	PAGE
		5.4 SUPPLEMENTAL INFORMATION	5-10
		SECTION - 6 - SERVICE AND MAINTENANCE	
3.6 TRANSPORT AND MANEUVERING (MOVING) . .	3-17	6.1 INTRODUCTION - MAINTENANCE SAFETY	
General	3-17	PRECAUTIONS	6-1
Fully Assembled Maneuvering	3-18	General	6-1
Disassembled Maneuvering	3-19	Maintenance Safety	6-2
Parking and Storage	3-20	6.2 MACHINE PREPARATION, INSPECTION AND	
Vehicle Transport.	3-20	MAINTENANCE	6-3
SECTION - 4 - EMERGENCY PROCEDURES		General	6-3
4.1 GENERAL INFORMATION	4-1	Preparation, Inspection, and Maintenance	6-3
Manual Descent Crank	4-1	Pre-Start Inspection	6-3
Discharged Battery	4-1	Frequent and Pre-Delivery Inspection	6-3
Operator Unable to Control Machine	4-2	Annual Machine Inspection	6-3
Platform Caught Overhead	4-3	5 Year Machine Inspection & Rope	
Rope Failure.	4-4	Replacement	6-4
4.2 INCIDENT NOTIFICATION	4-5	Preventive Maintenance	6-4
SECTION - 5 - GENERAL SPECIFICATIONS		6.3 PREVENTIVE MAINTENANCE AND INSPECTION	
5.1 INTRODUCTION	5-1	SCHEDULE	6-4
5.2 DECAL INSTALLATION.	5-1	6.4 SERVICING AND MAINTENANCE GUIDELINES .	6-8
5.3 GENERAL SPECIFICATIONS	5-7	General	6-8
Machine Specifications (assembled)	5-7	Safety and Workmanship.	6-8
Optional Powerpack Electrical Specifications. . .	5-8	Cleanliness	6-8
Platform Data.	5-9	Component Disassembly and Reassembly.	6-8
Machine Component Weights	5-10	6.5 REPLACEMENT KITS OVERVIEW.	6-9
Serial Number Locations	5-10	Manuals	6-11

TABLE OF CONTENTS

SECTION - PARAGRAPH, SUBJECT	PAGE	SECTION - PARAGRAPH, SUBJECT	PAGE
Country Kits	6-11	2-9. Tool tray installation	2-9
Leads	6-12	3-1. Main components	3-1
6.6 DECAL REPLACEMENT	6-13	3-2. Base frame component description	3-2
6.7 MAST ROPE INSPECTION PROCEDURE	6-14	3-3. Platform component description	3-3
1. Rope Wear	6-14	3-4. Mast/carriage component description	3-3
2. Rope Misaligned	6-14	3-5. Carriage/mast to base mounting	3-5
3. Rope Loose	6-15	3-6. Detail view of level bubble	3-5
SECTION - 7 - TROUBLESHOOTING		3-7. Attaching the platform to the carriage	3-6
7.1 GENERAL	7-1	3-8. Platform attachment checks	3-6
Troubleshooting Information	7-1	3-9. Cordless drill installation	3-7
SECTION - 8 - EC DECLARATIONS OF CONFORMITY		3-10. Powerpack positioned and latched into place	3-8
EC Declaration of Conformity - English	8-1	3-11. Tool tray load restriction	3-9
		3-12. Battery charging plug and tester	3-10
		3-13. Charge status lights	3-10
		3-14. Removing the battery from the powerpack	3-11
		3-15. Recharge dock operations and indicators	3-11
		3-16. Typical cordless drill interface devices	3-12
		3-17. Powerpack control console	3-13
		3-18. Cordless drill elevation	3-14
		3-19. Detail view of direction selector	3-15
		3-20. Detail view of enable & speed triggers	3-15
		3-21. Emergency stop button operation	3-16
		3-22. Activate the handle to extend the swivel castor	3-18
		3-23. Maneuvering when tilted back	3-18
		3-24. Mast/carriage handle	3-19

LIST OF FIGURES

1-1. Read your manual	1-2
2-1. Daily Walk-Around Inspection (Sheet 1 of 2)	2-5
2-2. Examples of cracks	2-5
2-3. Daily Walk-Around Inspection (Sheet 2 of 2)	2-6
2-4. Examples of new, acceptable and unacceptable ropes	2-7
2-5. Ropes retained in mast cap	2-7
2-6. Rope anchor points	2-7
2-7. Platform latch shown engaged	2-8
2-8. Location of manual descent crank	2-8

TABLE OF CONTENTS

SECTION - PARAGRAPH, SUBJECT	PAGE	SECTION - PARAGRAPH, SUBJECT	PAGE
4-1. Manual descent crank operation from inside platform	4-2		
4-2. Manual descent crank operation from outside platform	4-2		
4-3. Releasing the drive interlock using the lanyard	4-3		
5-1. Base Decal Installation - CE	5-3		
5-2. Carriage/Mast Decal Installation - CE	5-4		
5-3. Platform Decal Installation - CE	5-5		
5-4. Powerpack Decal Installation - CE	5-6		
6-1. Replacement Kits	6-9		
6-2. Drum view through inspection window	6-14		
6-3. Rope alignment through carriage	6-15		
6-4. Loose rope being re-tensioned	6-15		
LIST OF TABLES			
1-1 Minimum Approach Distances (M.A.D.)	1-5		
2-1 Inspection and Maintenance Table	2-3		
5-1 Decal Descriptions	5-2		
5-2 Machine Specifications (assembled)	5-7		
5-3 Optional Powerpack Electrical Specifications	5-8		
5-4 Platform Data	5-9		
5-5 Machine Component Weights	5-10		
6-1 Preventative Maintenance & Inspection Schedule	6-7		
7-1 Troubleshooting	7-4		

SECTION 1. SAFETY PRECAUTIONS

1.1 GENERAL

This section outlines the necessary precautions for proper and safe machine usage and maintenance. For proper machine use, it is mandatory that a daily routine is established based on the content of this manual. A maintenance program, using the information provided in this manual must also be established by a qualified person and must be followed to ensure that the machine is safe to operate.

Before operation, the operator shall:

1. Read and understand the manufacturer's operating instruction(s) and user's safety rules or have them explained.
2. Understand all labels, warnings and instructions displayed on the machine or have them explained.
3. Ensure all occupants of the machine wear appropriate personal protection equipment (PPE) for the conditions, including the environment in which the machine will be operated.

If there are any questions with regard to safety, training, inspection, maintenance, application, and operation, please contact JLG.

WARNING

FAILURE TO COMPLY WITH THE SAFETY PRECAUTIONS LISTED IN THIS MANUAL COULD RESULT IN MACHINE DAMAGE, PROPERTY DAMAGE, PERSONAL INJURY OR DEATH.

SECTION 1 - SAFETY PRECAUTIONS

1.2 PRE-OPERATION

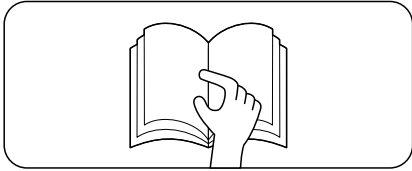

Figure 1-1. Read your manual

Operator Training and Knowledge

- Do not operate this machine until the operator has read and understood the Operation, Safety, Service and Maintenance Manual.
- Only competent personnel can operate the machine.
- Read, understand, and obey all DANGERS, WARNINGS, CAUTIONS, and operating instructions on the machine and in this manual.
- Use the machine in a manner which is within the scope of its intended application set by JLG.

- All operating personnel must be familiar with the emergency controls and emergency operation of the machine as specified in this manual.
- Read, understand, and obey all applicable employer, local, and governmental regulations as they pertain to operation of the machine.

Workplace Inspection

- The operator is to take safety measures to avoid all hazards in the work area prior to machine operation.
- Do not operate or raise the platform while on trucks, trailers, railway cars, floating vessels, scaffolds or other equipment unless approved in writing by JLG.
- This machine can be operated in temperatures of 0°C to 40°C (32°F to 104°F). Consult JLG for operation outside this range. Machine performance may vary from published specification in very hot or cold conditions.

Machine Inspection

- Before machine operation, perform inspections and functional checks. Refer to Section 2 of this manual for further instructions.
- Do not operate this machine until it has been serviced and maintained according to requirements specified in accordance with this manual.

 WARNING

MODIFICATION OR ALTERATION OF A MACHINE SHALL BE MADE ONLY WITH PRIOR WRITTEN PERMISSION FROM THE MANUFACTURER.

- Do not operate any machine on which the safety or instruction placards or decals are missing or illegible.
- Avoid any build up of debris on platform floor. Keep mud, oil, grease, and other slippery substances from footwear and platform floor.

1.3 OPERATION

General

- Do not use the machine for any purpose other than positioning personnel, their tools and equipment.
- Never operate a machine that is not working properly. If a malfunction occurs, shut down the machine and contact JLG.
- Never slam a control switch or lever through neutral to an opposite direction. Always return switch to neutral and stop before moving the switch to the next function. Operate controls with slow and even pressure.
- Do not allow personnel to tamper with, or operate the machine from the ground with personnel in the platform, except in an emergency.
- Do not carry materials directly on platform railing unless approved by JLG.
- Always ensure that power tools are properly stowed and never left hanging by their cord from the platform work area.
- Fully lower platform and shut off all power before leaving machine.
- No riders are permitted on the machine. Only the operator is permitted in the machine during operation.

SECTION 1 - SAFETY PRECAUTIONS

- When performing welding, cutting or grinding operations, avoid direct contact of heat, sparks and debris with the ropes and carriage drive assembly.
- Charge batteries only in a well ventilated area.

Vibrations emitted by this machine is not hazardous to an operator in the work platform. The equivalent continuous A-Weighted sound pressure level at the work platform is less than 70dB(A).

Trip and Fall Hazard

- Do not enter or leave the platform while elevated.
- JLG recommends that the operator utilises a fall restraint system in the platform with a maximum 36 inch (91.4cm) lanyard attached to the authorised lanyard anchorage point. For further information regarding fall protection requirements on JLG products, contact JLG.

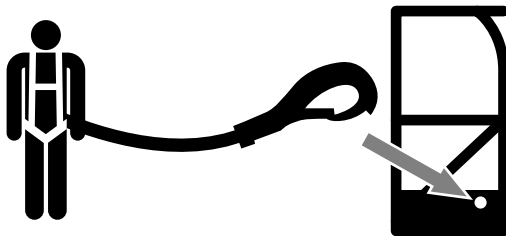

MAX = 36 in (1m)

- Before operating the machine, make sure all railings and gates are fastened in their proper position.
- Keep both feet firmly positioned on the platform floor at all times. Never use ladders, boxes, steps, planks, or similar items on platform to provide additional reach.

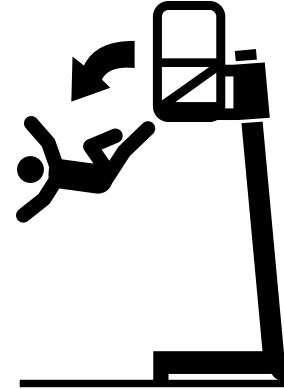

- Never use the mast assembly to enter or leave the platform.
- Use extreme caution when entering or leaving the platform. Ensure that the mast assembly is fully lowered. Face the machine when entering or leaving the platform.

SECTION 1 - SAFETY PRECAUTIONS

- Always maintain "three point contact" with the machine, using two hands and one foot or two feet and one hand at all times during entry and exit.

Electrocution Hazard

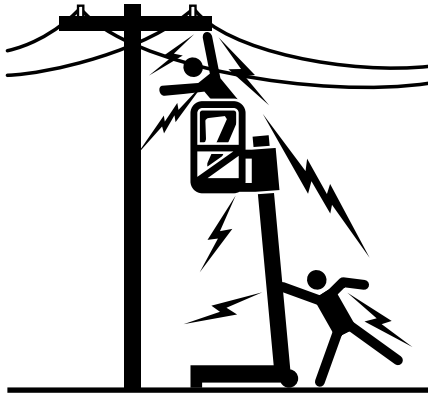

- This machine is not insulated and does not provide protection from contact or proximity to electrical current.
- Maintain distance from electrical lines, apparatus, or any energized (exposed or insulated) parts according to the Minimum Approach Distance (MAD) as shown in Table 1-1.

- Allow for machine movement and electrical line swaying.

Table 1-1. Minimum Approach Distances (M.A.D.)

VOLTAGE RANGE (PHASE TO PHASE)	MINIMUM SAFE APPROACH DISTANCE - Feet (Meters)
0-50KV	10 (3)
Over 50KV to 200KV	15 (5)
Over 200KV to 350KV	20 (6)
Over 350KV to 500KV	25 (8)
Over 500KV to 750KV	35 (11)
Over 750KV to 1000KV	45 (14)

NOTE: This requirement shall apply except where employer, local, or governmental regulations are more stringent.

- Maintain a clearance of at least 10 ft. (3m) between any part of the machine and its occupants, their tools, and their equipment from any electrical line or apparatus carrying up to 50,000 volts. One foot (0.3m) additional clearance is required for every additional 30,000 volts or less.
- The minimum safe approach distance may be reduced if insulating barriers are installed to prevent contact, and if the barriers are rated for the voltage of the line being

SECTION 1 - SAFETY PRECAUTIONS

guarded. These barriers shall not be part of (*or attached to*) the machine. The minimum safe approach distance shall be reduced to a distance within the designed working dimensions of the insulating barrier. This determination shall be made by a qualified person in accordance with employer, local, or governmental requirements for work practices near energized equipment.

⚠ DANGER

DO NOT MANEUVER MACHINE OR PERSONNEL INSIDE PROHIBITED ZONE (MAD). ASSUME ALL ELECTRICAL PARTS AND WIRING ARE ENERGIZED UNLESS KNOWN OTHERWISE.

Tipping Hazards

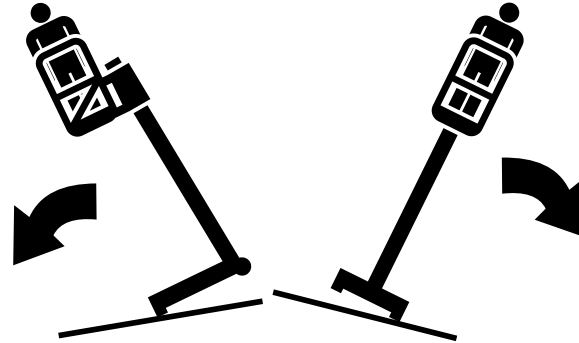

- Only elevate the platform on a firm and level surface.
- Check that the two wheels and the two adjustable feet are in contact with the ground prior to using the machine. Adjust the front feet to eliminate any base frame movement and check the bubble level indicates level prior to use.

SECTION 1 - SAFETY PRECAUTIONS

- Do not perform work that will subject unit to a horizontal force or create a swaying motion of the platform.

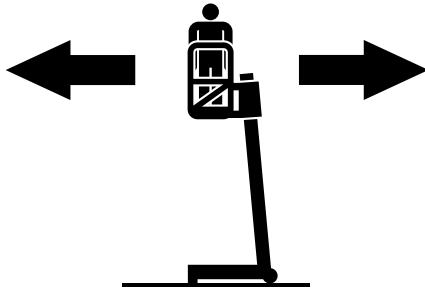

- Do not elevate if wind exceeds a gentle breeze (5m/s, Beaufort scale 3 - small twigs in constant motion/flags fly extended).
- The user should be familiar with the operating surface.
- Do not elevate platform while on a slope, or on an uneven or soft surface.
- Before using on floors, bridges, and other surfaces, check allowable capacity of the surfaces.
- Never exceed the maximum platform capacity. Distribute loads evenly on platform floor and tool tray.
- Keep the base of the machine a minimum of 0.6m (2 ft) from holes, bumps, drop-offs, obstructions, debris, con-

cealed holes, and other potential hazards at the ground level.

- Never attempt to use the machine as a crane. Do not tie-off machine to any adjacent structure.
- Do not increase the platform size with unauthorised extensions or attachments, increasing the area exposed to wind will decrease stability.
- If mast assembly or platform is caught so that one or more wheels are off the ground, the operator must be removed before attempting to free the machine. Use cranes, forklift trucks, or other appropriate equipment to stabilize machine and remove personnel.

Crushing and Collision Hazards

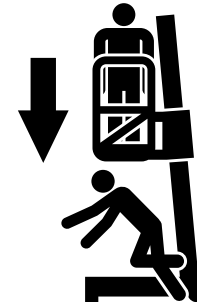

SECTION 1 - SAFETY PRECAUTIONS

- Appropriate personal protection equipment must be worn by all operating and ground personnel.
- Check work area clearances above, on sides, and bottom of platform while moving, lifting or lowering platform.
- During operation keep all body parts inside platform railing.
- Exercise extreme caution at all times to prevent obstacles from striking or interfering with operating controls and persons in the platform.
- Ensure that operators of other overhead and floor level machines are aware of the machine's presence. Disconnect power to overhead cranes.
- Warn personnel not to work, stand, or walk under a raised platform. Position barricades on floor as necessary.

1.4 MOVING, LIFTING AND REPOSITIONING

General

Never allow personnel in platform while moving, lifting or repositioning the machine.

This machine shall not be towed by a vehicle.

Ensure platform is fully retracted and completely empty of tools prior to disassembly, lifting or hauling.

Remove powerpack and tool tray (if fitted) from platform when transporting in a vehicle.

Refer to the Machine Operation section of this manual for lifting information.

Additional Safety Information

- Do not use machine as ground for welding.
- Keep all naked flames and sharp edges away from ropes.
- Do not attempt to transport assembled machinery by forklift.
- Avoid contact of the ropes with stem pipes and other hot surfaces

SECTION 2. PREPARATION AND INSPECTION

2.1 Personnel Requirements

This machine is a personnel handling device; so it is necessary that it be operated and maintained by competent personnel.

Persons under the influence of drugs or alcohol or who are subject to seizures, dizziness or loss of physical control must not operate this machine.

Operator Requirements

Before operating this machine the operator is required to have read and understood the Operation, Safety, Service and Maintenance Manual.

The operator must be familiar with:

1. Use and limitations of the controls in the platform and emergency controls.
2. Decals, instructions, and warnings on the machine.
3. Employer and government regulations.
4. Correct assembly of the machine.
5. Use of approved fall protection device.

6. Enough knowledge of the mechanical operation of the machine to recognize a malfunction or potential malfunction.
7. The safest means to operate the machine where overhead obstructions, other moving equipment, and obstacles, depressions, holes, drop-offs are present.
8. Means to avoid the hazards of unprotected electrical conductors.
9. Specific job requirements or machine application.

Operator Responsibility

The operator must shut down the machine in case of a malfunction or other unsafe condition of either the machine or the job site.

SECTION 2 - PREPARATION AND INSPECTION

2.2 Preparation, Inspection, and Maintenance

The following table covers the periodic machine inspections and maintenance recommended by JLG. Consult local regulations for any further requirements.

The frequency of inspections and maintenance must be increased as necessary when the machine is used in a harsh or hostile environment, if the machine is used with increased frequency, or if the machine is used in a severe manner.

SECTION 2 - PREPARATION AND INSPECTION

Table 2-1. Inspection and Maintenance Table

TYPE	FREQUENCY	PRIMARY RESPONSIBILITY	SERVICE QUALIFICATION	REFERENCE
Pre-Start Inspection	Before starting each day or at each workshift change	Operator	User or Operator	Operation, Safety, Service & Maintenance Manual
Frequent Inspection	In service for 3 months; out of service for a period of more than 3 months; or purchased used.	Owner, Dealer or User	Qualified Mechanic (*)	Operation, Safety, Service & Maintenance Manual and applicable JLG LiftPod inspection form
Annual Machine Inspection	Every 12 months	Owner, Dealer or User	Qualified Mechanic (*)	Operation, Safety, Service & Maintenance Manual and applicable JLG LiftPod inspection form
5 Year Replacement	When rope is worn or no more than 5 years from first use. Refer to Figure 2-4. for wear criteria.	Owner, Dealer or User	Authorized JLG Service Centre	Factory Training
NOTE: Use this manual to perform inspections.				
NOTE: (*) A person who has acquired by training, qualifications, experience or a combination of these, the knowledge and skill enabling the person to inspect and repair the machine to the level required by the complexity of the task.				

SECTION 2 - PREPARATION AND INSPECTION

Pre-Start Inspection

The Pre-Start Inspection should include each of the following:

1. **Cleanliness** – Check all surfaces for leakage, debris or foreign objects.
2. **Decals and Placards** – Check all for cleanliness and legibility. Make sure none of the decals and placards are missing. Make sure all illegible decals and placards are cleaned or replaced. (Reference Section 5.2, Decal Installation).
3. **Operation, Safety, Service & Maintenance Manual** – Make sure a copy of the Operation, Safety, Service & Maintenance Manual is enclosed in the weather resistant storage container.
4. **Assembly** – The machine must be fully assembled in accordance with Section 3.3.
5. **Walk-Around Inspection** – Refer to Section 2.3.
6. **Powerpack** – Charge as required (Section 3.4).
7. **Function Check** – Once the Walk-Around Inspection is complete, perform a function check of all systems in an area free of overhead and ground level obstructions. Refer to Section 2.4 for more specific instructions.

2.3 DAILY WALK-AROUND INSPECTION

Begin the Walk-Around Inspection at item one (1) as noted on the diagram Figure 2-1. Continue around machine checking each item in sequence for the conditions listed in the following check list.

WARNING

TO AVOID POSSIBLE INJURY, BE SURE DIRECTION SELECTOR IS IN THE “OFF” POSITION DURING WALK-AROUND INSPECTION. DO NOT OPERATE MACHINE UNTIL ALL MALFUNCTIONS HAVE BEEN CORRECTED.

NOTE: *Do not overlook visual inspection of the base frame underside. Check this area for objects, debris, corrosion and cracks.*

NOTE: *The mast and carriage components should be clean and free from oil, grease and dirt. Do not lubricate mast or carriage components, especially brake shoes.*

SECTION 2 - PREPARATION AND INSPECTION

Walk-Around Inspection Components

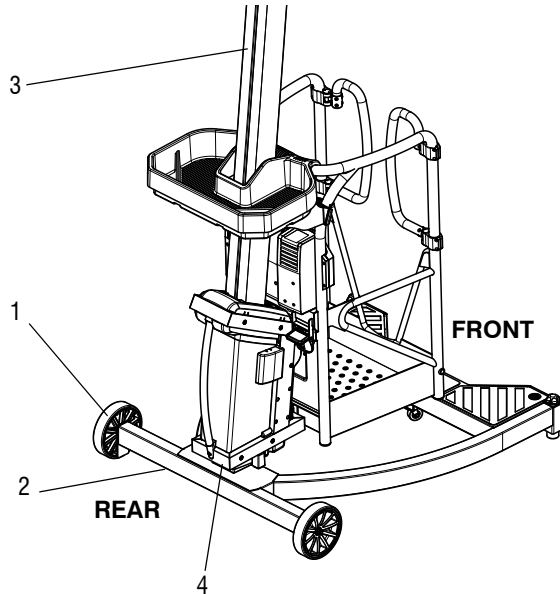

Figure 2-1. Daily Walk-Around Inspection
(Sheet 1 of 2)

NOTE: On all components, make sure there are no loose or missing parts, everything is securely fastened, no visible damage, or excessive wear exists in addition to any other criteria mentioned.

1. **Rear Wheels** - Check for any debris stuck to or around wheels. Make sure bolts are fastened.
2. **Base Frame** - Check for cracks or corrosion, especially around the mast-stump base (see Figure 2-2.). Check level bubble is clean and secure.
3. **Mast Assembly** - No cracks or corrosion, especially around base and flange; no excess wear, kinks, nicks or damage; carriage running surfaces smooth and unobstructed; free of dust, oil & grease.
4. **Carriage Frame** - check for visible cracks; check rollers for visible wear; check carriage frame welds for visible cracks (see Figure 2-2.).

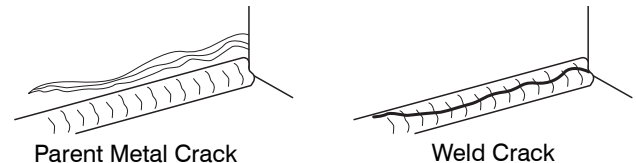

Figure 2-2. Examples of cracks

SECTION 2 - PREPARATION AND INSPECTION

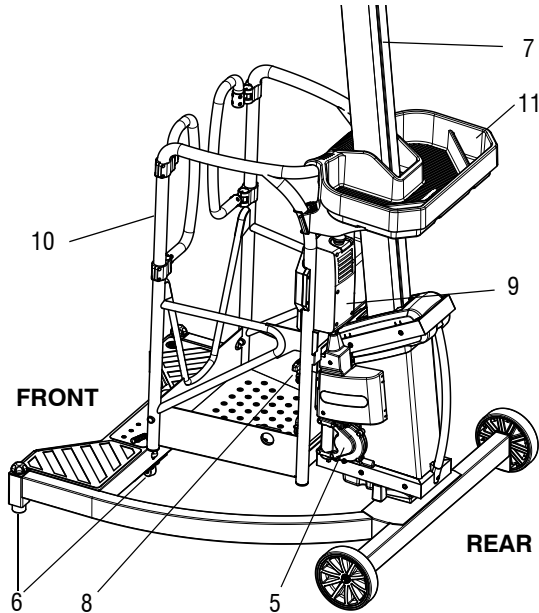

Figure 2-3. Daily Walk-Around Inspection
(Sheet 2 of 2)

5. **Gearbox** - check for any oil leaks, especially around bottom shaft seal.
6. **Swivel Castor Mechanism and Adjustable Feet** - Check for any debris stuck to or around wheels or mechanism. Check adjustable feet for damage. Rubber pads and tire must be in good order.
7. **Rope Assembly** - Check rope is not frayed or damaged (Figure 2-4.). Ensure it is tensioned tightly and seated properly around take-up drum (view via carriage inspection window - see Figure 6-2.). Ensure it is seated correctly over mast-cap (Figure 2-5.) and at anchor point at back of mast (Figure 2-6.). Indications that rope needs replacement include:
 1. Frayed or fluffy rope (Figure 2-4.)
 2. Braiding no longer visible
 3. Sections of rope thinned down in diameter.
8. **Manual Descent Crank** - Ensure it is present and securely attached (Figure 2-8.).
9. **Powerpack and Control Console (optional)** - Ensure it is properly mounted and secured. Button, triggers and switches not obscured or damaged; decals secure and legible; emergency stop switch reset for operation; control markings legible. Battery is installed and secure.

SECTION 2 - PREPARATION AND INSPECTION

10. **Platform Assembly and Gate** - Check mounting pins are not loose; platform railing is undamaged; platform latch is engaged on carriage (Figure 2-7.); self-closing entry gates are in proper working order; no cracks or corrosion visible.
11. **Tool Tray** - See next page for Tool Tray Pre-Start Inspection Procedure.



Figure 2-4. Examples of new, acceptable and unacceptable ropes

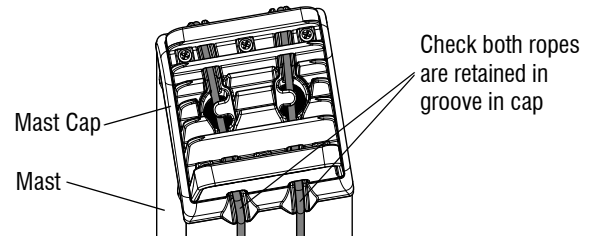

Figure 2-5. Ropes retained in mast cap

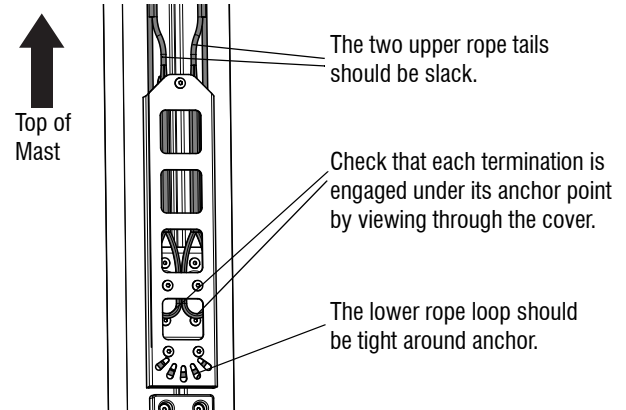

Figure 2-6. Rope anchor points

SECTION 2 - PREPARATION AND INSPECTION

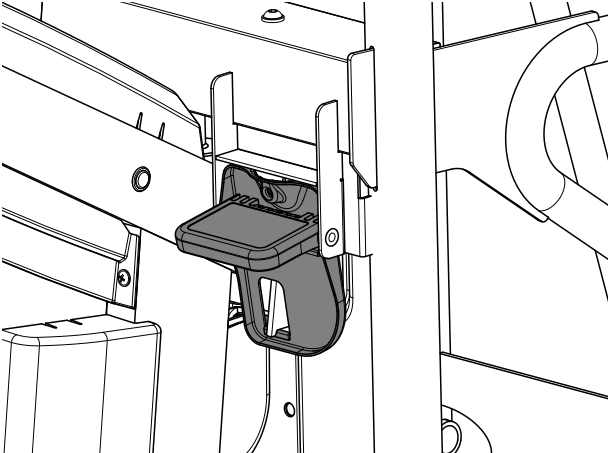

Figure 2-7. Platform latch shown engaged

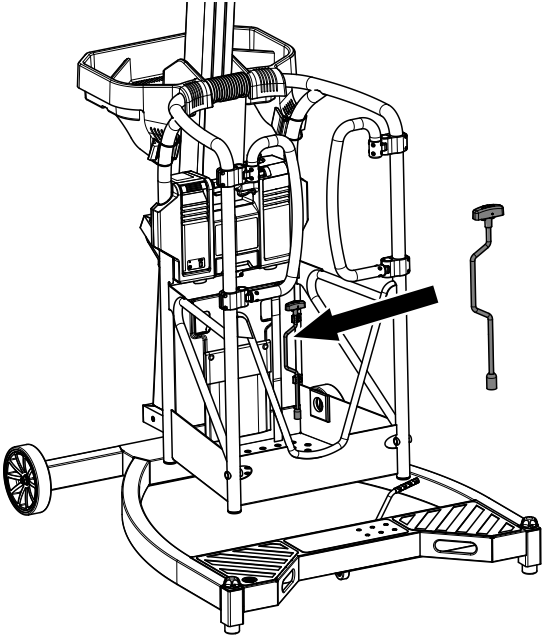

Figure 2-8. Location of manual descent crank

Tool Tray Pre-Start Inspection

Prior to use of the tool tray, check the following:

- Tool tray is seated securely on the platform rail.
- No cracks or bends in tray.
- Both of the clips are securely attached to the platform rail (Figure 2-9).
- Capacity decal is in place and legible.

Maximum Load: The maximum permissible load on the tool tray is 15kg (33 lb.) evenly distributed.

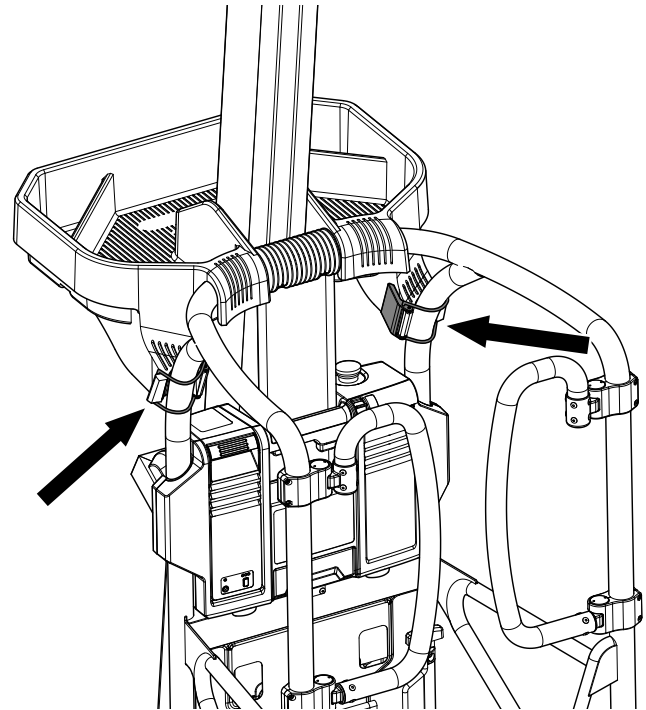

Figure 2-9. Tool tray installation

SECTION 2 - PREPARATION AND INSPECTION

2.4 FUNCTION CHECK

Once the Walk-Around inspection is complete, perform a function check of all systems in an area free of overhead and ground level obstructions.

WARNING

IF THE MACHINE DOES NOT OPERATE PROPERLY, TURN OFF THE MACHINE IMMEDIATELY! REPORT THE PROBLEM TO THE PROPER MAINTENANCE PERSONNEL. DO NOT OPERATE THE MACHINE UNTIL IT IS DEEMED SAFE FOR OPERATION.

Function Check Items

1. **Base Brake** - Step on base to ensure the swivel castor retracts properly.
2. **Adjustable Feet** - Check both rotate freely up and down; check that rubber pads are installed and not excessively worn.
3. **Emergency Stop Button** (optional powerpack) - ensure all machine functions are disabled when the emergency stop button is activated (pressed in) - then **RESET** the emergency stop button by twisting it in the direction indicated by the arrows.

WARNING

TO AVOID COLLISION AND INJURY IF PLATFORM DOES NOT STOP WHEN A CONTROL IS RELEASED, USE THE EMERGENCY STOP BUTTON TO STOP THE MACHINE.

SECTION 3. MACHINE OPERATION

3.1 GENERAL

NOTE: *The manufacturer has no direct control over machine application and operation. The user and operator are responsible for conforming with good safety practices.*

This section provides the necessary information needed to understand control function and operation.

3.2 MACHINE DESCRIPTION

The JLG LiftPod is a battery powered portable personnel platform. The platform is mounted to a mast and elevating carriage mechanism. The personnel lift's intended purpose is to provide personnel access to areas above level ground. The platform must only be elevated on a firm, level, uniform surface.

The machine consists of seven parts:

- 1. Base Frame
- 2. Carriage/Mast Assembly
- 3. Platform
- 4. Powerpack (optional)
- 5. Spare Battery (optional)

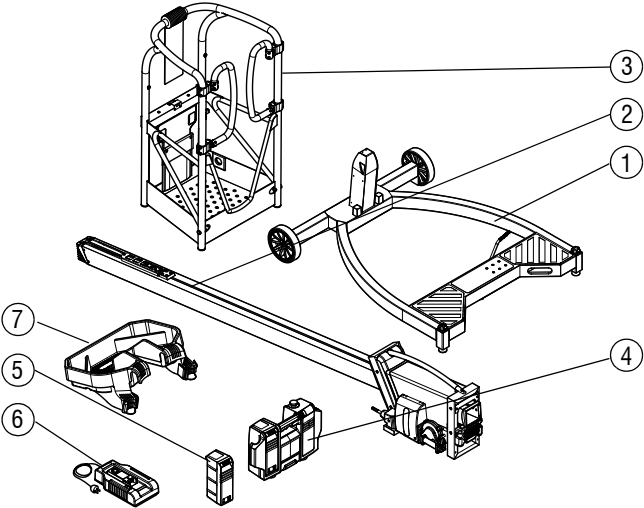

Figure 3-1. Main components

- 6. Charger (optional)
- 7. Tool Tray (optional)

SECTION 3 - MACHINE OPERATION

The primary control console is located within the removable and rechargeable powerpack.

The powerpack is attached to the machine within the platform.

With the installed powerpack, the operator can raise or lower the platform through its controls.

The machine has a self retracting swivel castor mounted under the front of the base which retracts out of ground contact when loaded.

The base of the machine consists of two fixed wheels and two adjustable feet, for leveling and stabilizing the base within 2 degrees of level from front and back only. Prior to operation the adjustable feet are to be engaged to a point where the base is level as seen on the level bubble (Figure 3-6).

Detailed Description

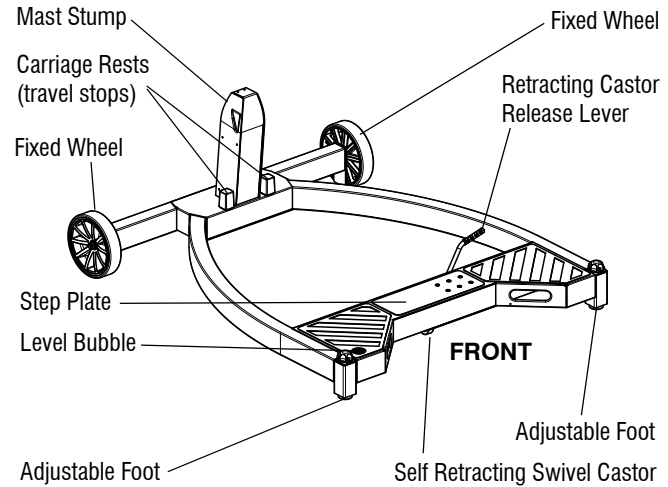

Figure 3-2. Base frame component description

Platform Configuration

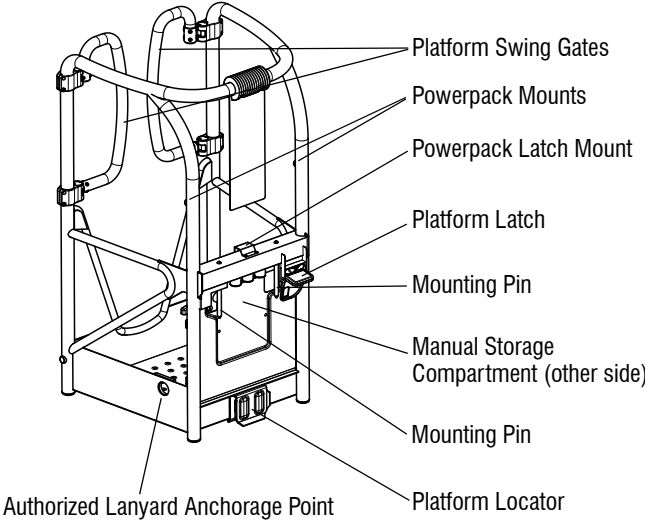

Figure 3-3. Platform component description

Mast/Carriage Components

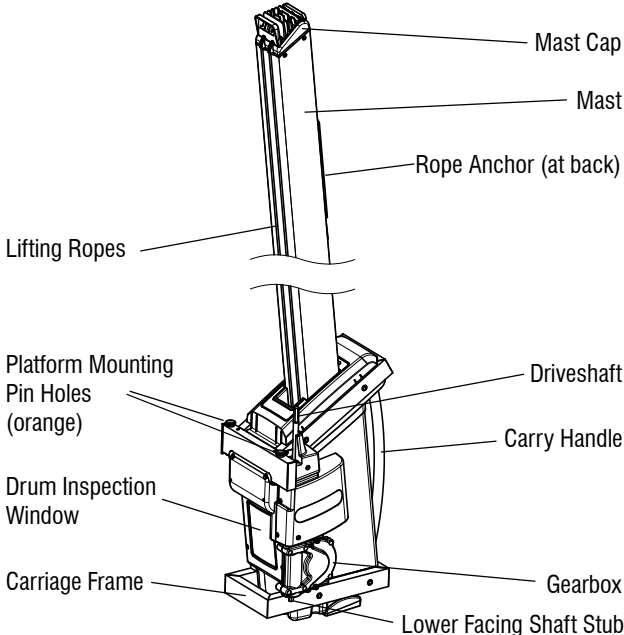

Figure 3-4. Mast/carriage component description

SECTION 3 - MACHINE OPERATION

3.3 MACHINE OPERATION

General

When the platform reaches the bottom of its travel, the rest position, the drive mechanism overrunning clutch creates a ratcheting, or buzzing noise, indicating that the machine has reached the fully lowered position.

The machine is fitted with an emergency brake which activates when the tension in the lifting ropes goes below 40kg (88 lbs).

When the platform is lowered to the rest position, the emergency brake swings into position, stopping further rotation of the rope drum and engaging a carriage lock-down latch onto the mast.

⚠ WARNING

IN THE EVENT THAT THE CARRIAGE LATCHES TO THE MAST WHEN FULLY LOADED OR THE ROPE CONTINUES TO FEED OUT AFTER THE PLATFORM HAS REACHED THE REST POSITION, THE MACHINE IS NOT WORKING PROPERLY AND MUST NOT BE USED UNTIL IT IS INSPECTED AND REPAIRED BY A QUALIFIED PERSON.

NOTE: *Do not attempt to lift the mast off the base unless the carriage has been fully lowered.*

Getting Started

The following control conditions must be met before the machine can be operated from the platform controls:

- Batteries must contain enough voltage to operate. Low battery warning on battery test panel indicates the need to charge the batteries. **Batteries should be charged for 24 hours prior to first use.**
- Emergency stop switch on optional powerpack must be in the **RESET** position (out).
- Both platform swing-in entry gates must be closed.

Assembly of the Machine

The JLG LiftPod is a user assembled machine. There are three basic parts that need to be assembled for operation. These parts are the Base Frame **1**, Carriage/Mast Assembly **2**, and the Platform **3**. Optional parts include the Powerpack **4**, and the Tool Tray **5** (Figure 3-1.).

1. Position the base frame on a firm, level, uniform, supporting surface.
2. Push down on the base frame's step plate until the swivel castor retracts and the base sits on the adjustable feet (Figure 3-5.). The machine now rests on the two rear wheels, and the two adjustable feet at the front.

SECTION 3 - MACHINE OPERATION

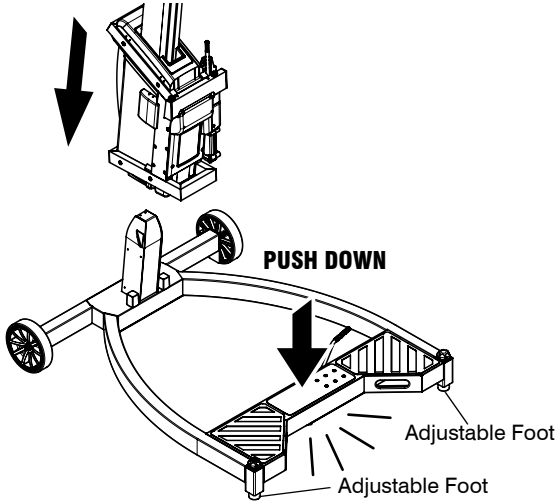

Figure 3-5. Carriage/mast to base mounting

⚠ WARNING

CRUSH HAZARD - KEEP FEET CLEAR OF ADJUSTABLE FEET AND UNDERNEATH BASE WHEN STEPPING ON BASE TO RETRACT CASTOR.

- 3. Turn the adjustable feet until the level bubble is centred (see Figure 3-6.)

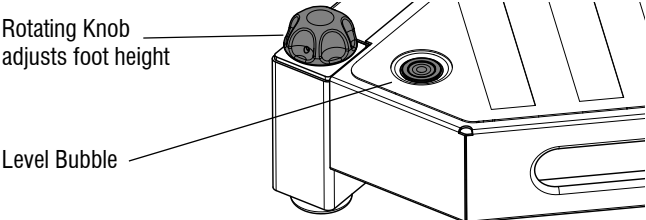

Figure 3-6. Detail view of level bubble

⚠ WARNING

DO NOT USE THE MACHINE IF THE BASE CAN NOT BE LEVELLED.

SECTION 3 - MACHINE OPERATION

- Slide the carriage/mast assembly onto the mast stump.
Make sure it is properly aligned and fully engaged.
Never force it into position (see Figure 3-5.).

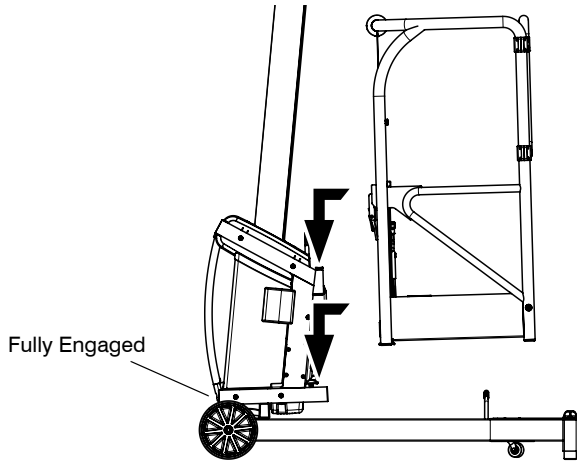

Figure 3-7. Attaching the platform to the carriage

- Attach the platform to the carriage (see Figure 3-7.).
 - Make sure the platform's mounting pins are aligned with the holes in the carriage (A), then drop slowly down to seat properly.

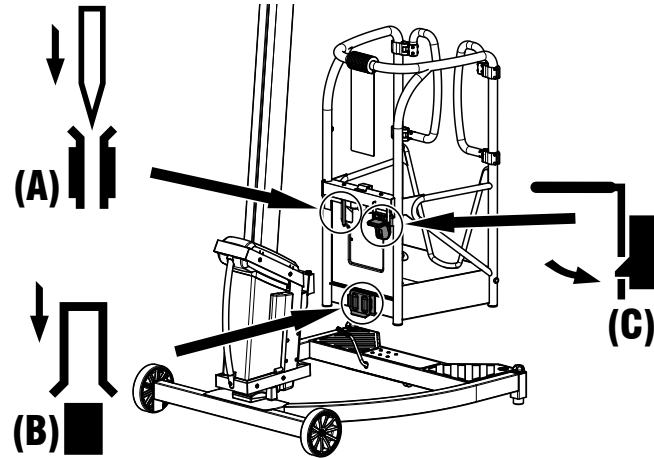

Figure 3-8. Platform attachment checks

- Ensure the platform locator (B) is properly engaged in the bottom of the carriage frame.
- Make sure the platform latch (C) is fully engaged. **CHECK: Try to lift the platform out, if it does not release, then the platform has engaged properly.**

NOTE: When reversing the procedure to disassemble the machine, pull the platform latch handle (C) to disengage the platform from the carriage.

- 6. Fasten lanyard securely around the handle of the cordless drill. Attach the cordless drill to the top of the driveshaft, either using the supplied 7/16 (11mm) deep well drive socket (located in manual pouch), or by tightening the drill chuck directly to the hexagon on top of the driveshaft (see Figure 3-9).

⚠ WARNING

**CORDLESS DRILL LANYARD MUST BE INSTALLED BEFORE ELEVATING.
DO NOT DROP DRILL.**

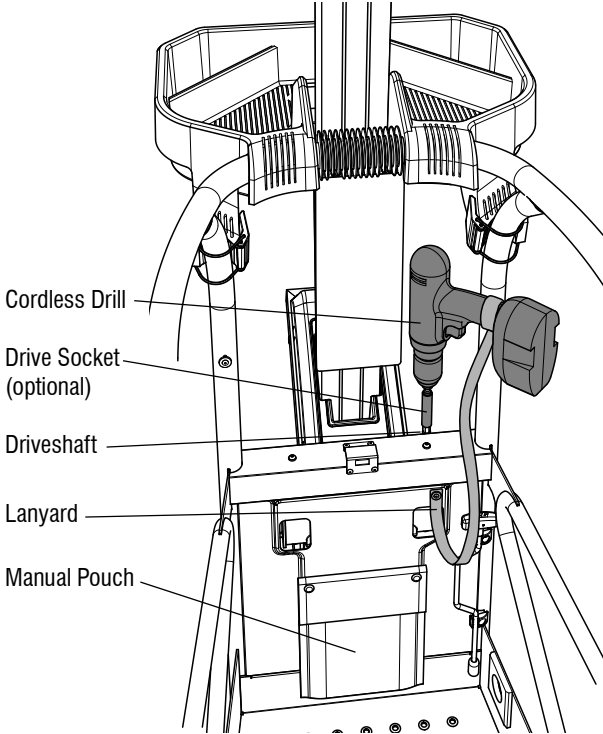

Figure 3-9. Cordless drill installation

SECTION 3 - MACHINE OPERATION

7. Place the powerpack (optional equipment) against the platform uprights, closest to the mast, and slide it down until it clicks, indicating it is fully seated (see Figure 3-10.).

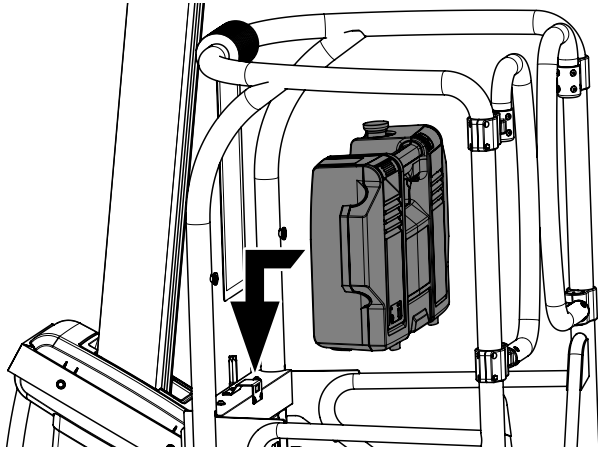

Figure 3-10. Powerpack positioned and latched into place

NOTE: When reversing the procedure to disassemble the machine, pull the powerpack release latch (see Figure 3-17.) while lifting to disengage the powerpack from the platform.

8. Tool tray: (optional equipment)
Place on top rail of platform, and fasten the two clips firmly around the rail (see Figure 2-9.).

⚠ WARNING

THE WEIGHT OF OBJECTS CARRIED IN A PLATFORM ACCESSORY, ALONG WITH PERSONNEL AND EQUIPMENT PLACED IN THE PLATFORM MUST NOT EXCEED THE MAXIMUM RATED PLATFORM CAPACITY. SEE TABLE 5-4.

⚠ WARNING

DO NOT PLACE ITEMS IN THE TOOL TRAY IN THE INDICATED AREA WHEN MAST IS BELOW THE TOOL TRAY'S TOP SURFACE (SEE FIGURE 3-11.).

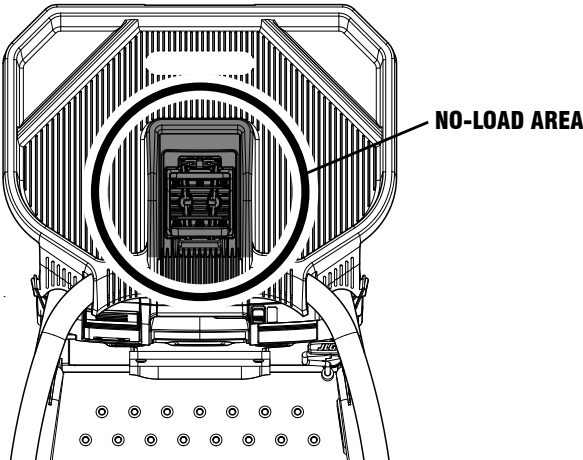

Figure 3-11. Tool tray load restriction

Disassembly of the Machine

Reverse the above steps to disassemble the machine.

⚠ WARNING

DO NOT ATTEMPT TO LIFT THE MAST OFF THE BASE UNLESS THE CARRIAGE HAS BEEN FULLY LOWERED.

3.4 Powerpack (Optional Equipment)

Battery Charging Operation

⚠ WARNING

DO NOT SHORT CIRCUIT THE BATTERY. DO NOT OPEN THE BATTERY PACK AS THERE IS A DANGER OF CAUSING A SHORT CIRCUIT. PROTECT THE BATTERY AGAINST HEAT, INCLUDING AGAINST CONTINUOUS DIRECT SUN EXPOSURE OR OPEN FLAME.

New batteries and batteries that have not been used for a long period must be fully charged. They will not reach their full capacity until fully charged and discharged through several cycles. Battery performance will be limited at low temperatures. The battery can be charged and discharged hundreds of times but will eventually wear out and need to be replaced. A significantly reduced operating period after charging indicates that the battery must be replaced.

Battery Charge Status Lights

The powerpack batteries indicates battery low voltage at three (3) warning levels.

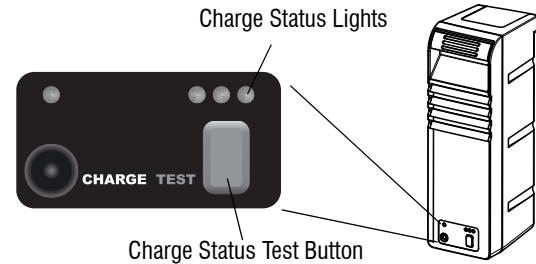

Figure 3-12. Battery charging plug and tester

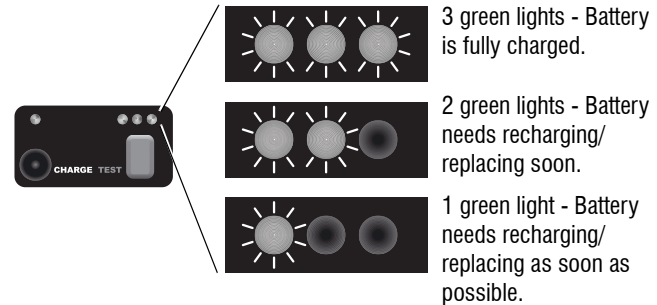

Figure 3-13. Charge status lights

Charging the Batteries Using the Fast Charge Station

NOTE: USE ONLY THE SUPPLIED CHARGING STATION.

- 1. Remove battery from powerpack (Figure 3-14.).
- 2. Place battery into recharging dock.

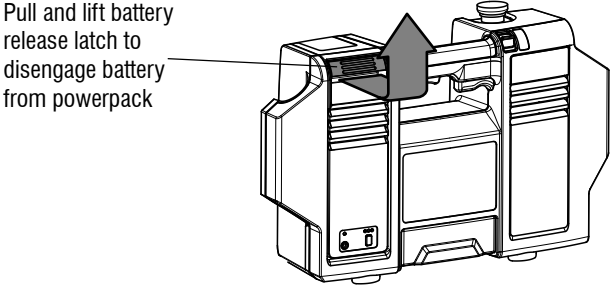

Figure 3-14. Removing the battery from the powerpack

- 3. Plug recharge dock into AC voltage wall outlet.
- 4. Once the green LED has stopped flashing, the powerpack is fully charged.

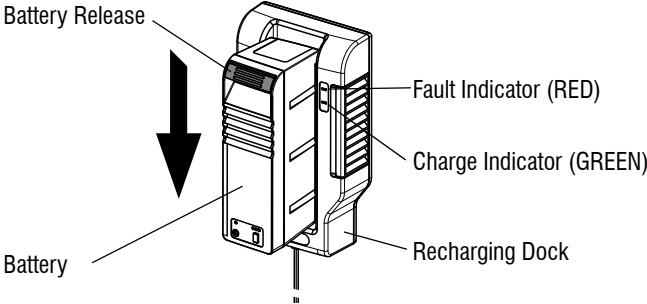

Figure 3-15. Recharge dock operations and indicators

⚠ DANGER

TO REDUCE THE RISK OF FIRE OR ELECTRIC SHOCK, CAREFULLY FOLLOW THESE INSTRUCTIONS.

If the shape of the plug does not fit the power outlet, use an attachment plug adaptor of the proper configuration for the power outlet.

If the supply cord is damaged, it must be replaced by a special cord or assembly available from the manufacturer or its service agent. See Section 6.

Unless the battery is being charged, always remove the battery from the fast charger.

SECTION 3 - MACHINE OPERATION

Fast Charge Indicator Light Guide

SOLID GREEN: Insert battery or remove fully charged battery

FLASHING GREEN: Battery is charging.

SOLID RED: Charging is temporarily halted to allow battery to cool down. Charging will continue automatically.

FLASHING RED: Please reinsert battery. If the red light continues to flash, the battery or the charger may be faulty.

To troubleshoot whether the battery or the charger is at fault, insert another battery. If this battery charges, the other battery is faulty and must not be used. If the red light continues to flash, the charger is faulty.

3.5 Operation

Cordless Drill

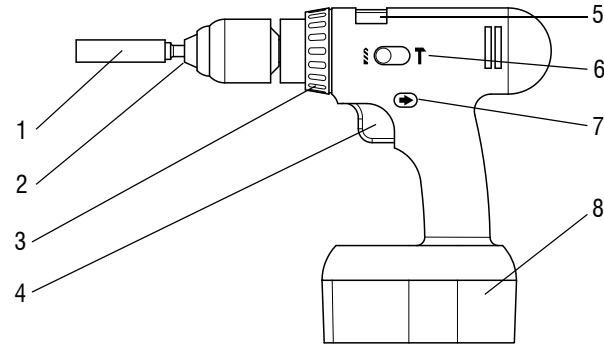

Figure 3-16. Typical cordless drill interface devices

1. Drive Socket (optional)
2. Chuck
3. Torque Control (optional)
4. Power Trigger
5. Speed Controller (optional)
6. Drill/Hammer Function Selector (optional)

7. Direction Selector

8. Battery Pack

Please follow the manufacturer's instructions on safe operation and maintenance of the cordless drill.

JLG recommends a cordless drill of at least 18V capacity.

Ensure cordless drill's optional "Hammer" setting is disabled and cordless drill is in "Drill" mode on medium to high torque. Do not set to maximum torque setting.

⚠ WARNING

USE ONLY CORDLESS DRILLS. DISCONTINUE USE OF THE CORDLESS DRILL IF A FAULT IS DETECTED. ENSURE CORDLESS DRILL IS IN "DRILL" MODE ON MEDIUM TO HIGH TORQUE SETTING, BUT NOT MAXIMUM TORQUE SETTING TO AVOID INJURY.

Powerpack Control Console (Optional Equipment)

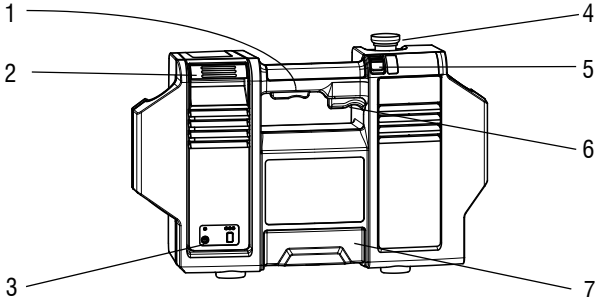

Figure 3-17. Powerpack control console

- 1. Enable Trigger**
- 2. Battery Release Latch**
- 3. Battery Trickle Charge Plug**
- 4. Emergency Stop Button**
- 5. Direction Selector**
- 6. Speed Trigger**
- 7. Powerpack Release Latch**

SECTION 3 - MACHINE OPERATION

The powerpack is splash resistant allowing a safe descent if it starts to rain while the unit is elevated, but JLG does not recommend that the powerpack be used in rain or exposed to water.

Whenever the machine is not in use, set the direction selector to the **OFF** position.

⚠ WARNING

DISCONTINUE USE OF THE POWERPACK IF A FAULT IS DETECTED.

NOTICE

DO NOT PRESSURE-WASH THE POWERPACK.

MAKE SURE YOU CHECK THE REMAINING CHARGE INSIDE THE POWERPACK'S BATTERY BEFORE ELEVATING THE PLATFORM BY PRESSING THE CHARGE INDICATOR TEST BUTTON. IF ONLY ONE LIGHT COMES ON, REPLACE WITH FULLY CHARGED BATTERY.

NOTICE

IF THE POWERPACK DOES NOT ACTIVATE WITH A CHARGED BATTERY INSTALLED, THE EMERGENCY BUTTON MAY NEED TO BE RESET (TWIST IN DIRECTION OF ARROWS AND POP OUT).

Elevating

Make sure the pre-start inspection has been completed, the machine is safe to use, and the base is level.

Move the cordless drill's direction selector to the "screw-in" (clockwise) direction.

Hold the drill's handle firmly, push it down to automatically disengage the driveshaft interlock, and squeeze the trigger to elevate.

Stop using the cordless drill if any part of it becomes excessively hot. Wait until drill has cooled down and then continue operation.

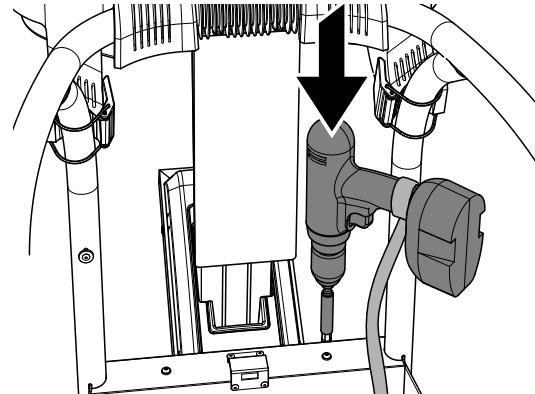

Figure 3-18. Cordless drill elevation

SECTION 3 - MACHINE OPERATION

If using the optional powerpack instead of a cordless drill, move the direction selector switch to the **UP** position (Figure 3-19).

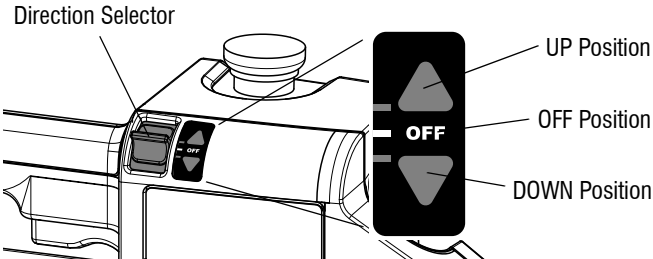

Figure 3-19. Detail view of direction selector

Hold the handle so the enable trigger is pressed and squeeze the speed trigger. The function speed is proportional to how far the speed trigger is pressed.

To stop, simply release the speed trigger. A slow release makes the platform come to a smooth stop.

Most cordless drills and the motor in the powerpack are fitted with thermal overload protection. In case of overheating, this cuts power to the motor. The cutout automatically resets itself when the motor has cooled down, allowing normal operation to resume. Depending on ambient temperature this can take 5 to 30 minutes. Engaging the triggers to run the cooling fan will decrease the thermal reset time.

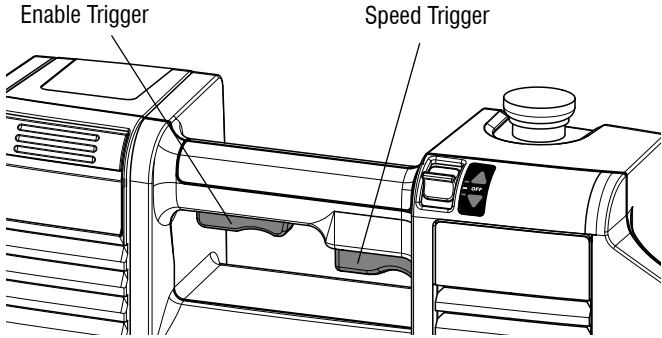

Figure 3-20. Detail view of enable & speed triggers

The manual descent procedure (Section 4.1) can be used to lower the platform if required.

- Do not attempt to elevate with no load in the platform.
- The platform has a total capacity of **150kg (330 lb.)**.
- The machine is not intended for use by children.
- Children must be supervised to ensure they do not use or play with the machine.
- Only **one** person is allowed to be lifted by the platform.



SECTION 3 - MACHINE OPERATION

Descending

⚠ WARNING

CRUSHING HAZARD - BE AWARE OF DESCENDING PLATFORM WHEN LOWERING THE PLATFORM. KEEP HANDS OR FEET OFF THE MAST ASSEMBLY AND FROM BENEATH PLATFORM.

On the cordless drill, move the direction selector to the "unscrew" (anti-clockwise) direction. Push the cordless drill down to disengage the driveshaft interlock and squeeze the trigger to descend.

If using the optional powerpack, move the direction selector to the **DOWN** position. Hold the handle so the enable trigger is pressed and squeeze the speed trigger.

To stop at anytime, simply release the speed trigger.

To exit the platform, ensure the platform is all the way down until it touches-down on the base. This will engage the drive mechanism's overdrive ratchet, making a ratcheting sound. This means the platform has reached its lowest position and the trigger should be released.

NOTE: Before transporting, maneuvering or disassembling machine, ensure the platform is all the way down. The carriage lock is engaged automatically when the platform is fully lowered and all load is removed.

Powerpack Emergency Stop/Shutdown Button

If the platform stops responding to operator input at any time while the platform is moving, use the emergency stop button to cut the power to the motor.

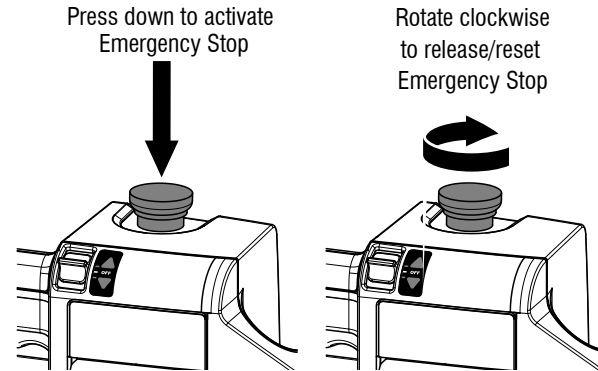

Figure 3-21. Emergency stop button operation

Unpowered Descent

The platform manual descent crank (Figure 2-8.) is provided to:

- Allow the platform operator to lower the platform in the event that the cordless drill or powerpack batteries run out of sufficient charge to lower the platform;
- Allow ground personnel to lower the platform in event that the platform operator becomes incapacitated.

For emergency operation please see Section 4 - Emergency Procedures.

3.6 TRANSPORT AND MANEUVERING (MOVING)

General

The machine may be manually maneuvered or transported in a vehicle disassembled.



DO NOT ATTEMPT TO TRANSPORT OR MOVE MACHINE UNLESS THE CARRIAGE IS FULLY DOWN AND THE CARRIAGE TO MAST LOCK IS ENGAGED. DO NOT MOVE MACHINE WITH PERSONNEL IN PLATFORM.



WHEN TRANSPORTING THE MACHINE, ENSURE THE ROPES ARE PROTECTED AND NOT DAMAGED.

The machine may be moved around a worksite using the following methods:

- Fully assembled, pushed around the floor using the wheels and castor;
- Fully assembled, tilted over.
- Disassembled, with each major component carried separately.

SECTION 3 - MACHINE OPERATION

Fully Assembled Maneuvering

There are two ways to move the assembled machine:

PUSHED UPRIGHT

The machine can be pushed around using the built-in wheels and castor. The floor is required to be smooth, level, clean and dry. There can be no significant load on the machine while it is being rolled around, or the swivel castor will retract automatically.

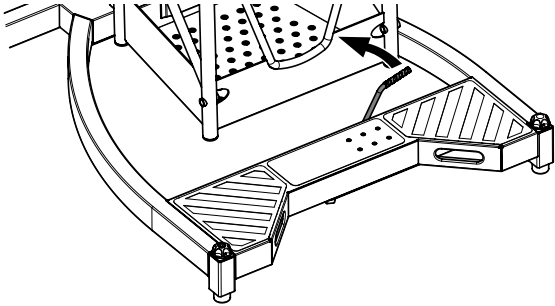

Figure 3-22. Activate the handle to extend the swivel castor

Lift the handle to engage the swivel castor.

The machine is easily positioned as required.

The swivel castor underneath the step plate toggles out of the way when loaded, and the machine rests securely on the rear wheels and two adjustable feet.

PUSHED TILTED OVER

The machine can be tilted over and maneuvered as shown in Figure 3-23.

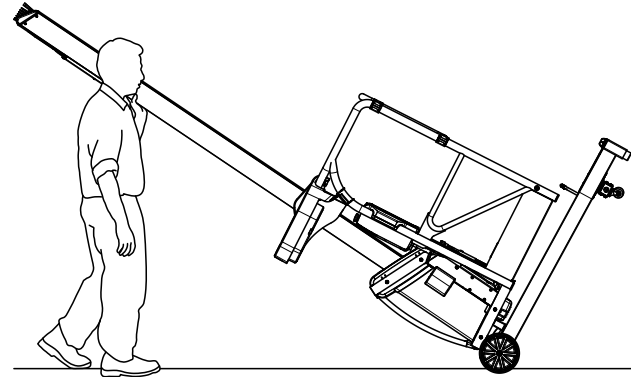

Figure 3-23. Maneuvering when tilted back

NOTE: *Ensure powerpack and tool tray are securely attached and tool tray and platform are empty before moving.*

⚠ CAUTION

ONLY ATTEMPT TO TILT THE UNIT BACK, OR RETURN TILTED UNIT TO THE UPRIGHT POSITION, ON A FLAT AND LEVEL SURFACE, CLEAR OF ANY PERSONNEL. ENSURE A FIRM GRIP WITH TWO HANDS ON THE MAST, AND ENSURE WEIGHT IS DISTRIBUTED TO AVOID THE USER OR THE MACHINE BEING THROWN BY THE MOVING WEIGHT OF THE MACHINE.

Disassembled Maneuvering

The machine is designed to be used and assembled by a single operator. To improve portability, it is divided into a number of self contained sub-assemblies (see Figure 3-1.).

⚠ WARNING

TAKE PRECAUTIONS TO AVOID MANUAL HANDLING INJURIES. USE PROPER LIFTING TECHNIQUES: BEND AT KNEES ONLY, NEVER TWIST YOUR BACK WHEN HOLDING OR CARRYING A LOAD, AND/OR GET HELP. ONLY CARRY ONE COMPONENT AT A TIME.

The mast/carriage assembly can be carried by the built-in handle (see Figure 3-24.).

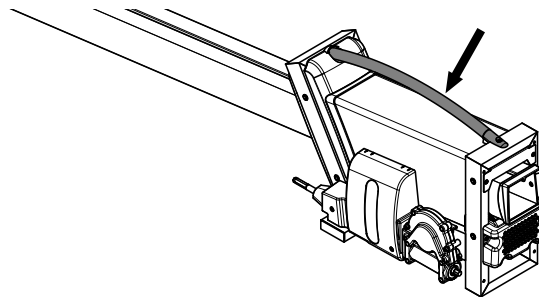

Figure 3-24. Mast/carriage handle

SECTION 3 - MACHINE OPERATION

Parking and Storage

- Move machine to a dry, well-protected and well-ventilated area out of direct sunlight.
- Ensure the platform is fully lowered. If installed, move the powerpack's direction control switch to the **OFF** position.
- If necessary, remove the cordless drill or optional powerpack from the platform to prevent unauthorized use.
- Ensure the swivel castor is retracted and the machine is resting on the adjustable feet.

NOTICE

DO NOT STORE IN LOCATIONS WHERE THE MACHINE MAY ACCUMULATE ICE, GREASE OR AIRBOURNE DEBRIS.

Vehicle Transport

When transporting the machine by vehicle, it should be disassembled into its major components (see Figure 3-1.) and each component secured separately. Restrain each component of the machine securely during transport. Ensure the swivel castor is retracted in the base frame and the base frame is resting on the adjustable feet.

NOTICE

USE OF EXCESSIVE FORCE WHEN SECURING MACHINE CAN CAUSE DAMAGE TO THE MACHINE.

Secure machine to the transport vehicle with adequately rated rope or straps. Do not overtension such devices and place a buffer between the device and any part of the machine.

SECTION 4. EMERGENCY PROCEDURES

4.1 GENERAL INFORMATION

This section explains the steps to be taken in case of an emergency situation during operation.

Manual Descent Crank

The platform manual descent crank is provided to:

- Allow the platform operator to lower the platform in the event that the cordless drill or powerpack batteries run out of sufficient charge to lower the platform;
- Allow ground personnel to lower the platform in the event that the platform operator cannot lower the platform once elevated.

NOTICE

THE CRANK IS DESIGNED FOR DESCENT IN CASE OF LOSS OF POWER ONLY. IT MUST NOT BE USED TO ELEVATE THE PLATFORM OR FOR GENERAL OPERATIONS.

⚠ WARNING

IF THE BATTERIES ARE DISCHARGED WHILE THE UNIT IS ELEVATED, DO NOT CLIMB OUT OF THE PLATFORM. USE THE MANUAL DESCENT CRANK.

Discharged Battery

If the battery should run out of charge before the platform has fully descended:

1. Remove the cordless drill and place it inside the platform. If the optional powerpack is installed, remove it and place it sideways against the back panel in the platform (see Figure 4-1.).
2. Remove the manual descent crank from the mounting clips inside the platform.
3. Engage the hexagon at the top of the driveshaft with the socket end of the manual crank.
4. Push down on top of the handle to disengage the driveshaft lock and wind anti clockwise until the platform comes to rest against the stops on the base.

SECTION 4 - EMERGENCY PROCEDURES

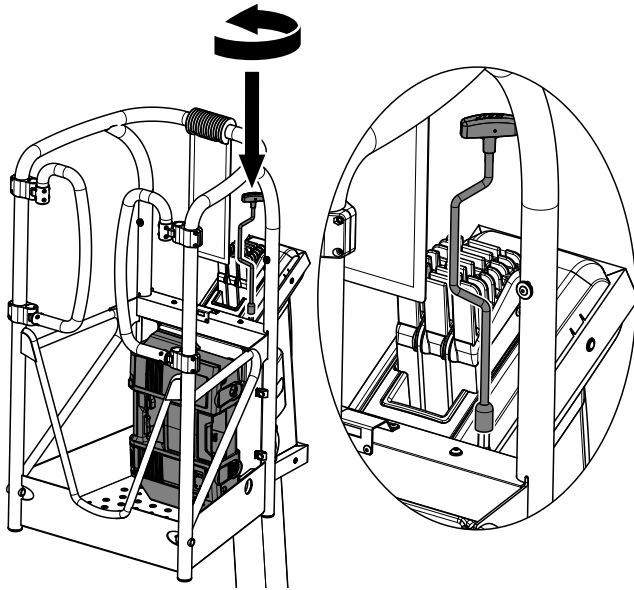
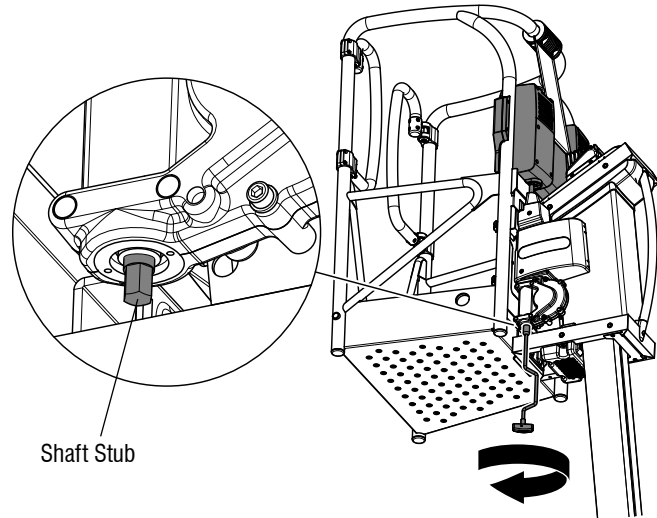

Figure 4-1. Manual descent crank operation from inside platform

Operator Unable to Control Machine

If the platform operator is pinned, trapped or unable to operate or control the machine other personnel should operate the machine from ground using the manual descent crank on the lower facing shaft stub.



Shaft Stub

Figure 4-2. Manual descent crank operation from outside platform

NOTICE

IF THE OPTIONAL POWERPACK IS NOT INSTALLED, USE THE LANYARD IN THE PLATFORM TO SECURE THE DRIVESHAFT IN A DEPRESSED (PUSHED-IN) POSITION, RELEASING THE DRIVE INTERLOCK.

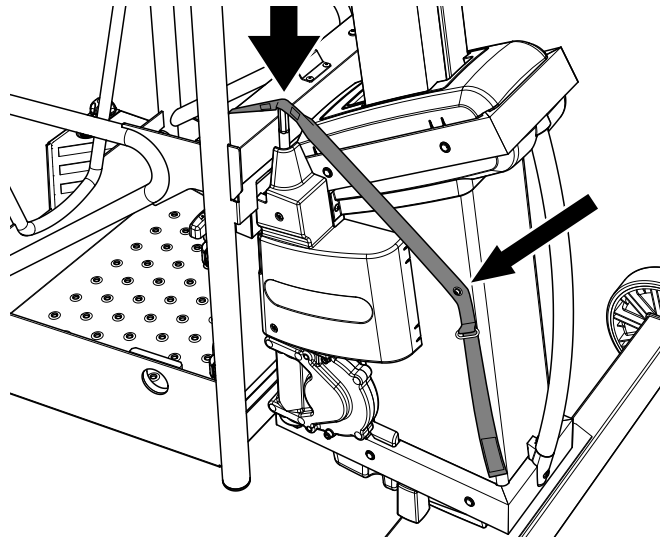

Figure 4-3. Releasing the drive interlock using the lanyard

⚠ WARNING

DO NOT ACTIVATE THE POWERPACK WHILE THE MANUAL DESCENT CRANK IS ATTACHED.

Platform Caught Overhead

If the platform becomes jammed or snagged in overhead structures or equipment, rescue the platform occupant prior to freeing the machine.

Rescue equipment can be used to remove the platform occupant. Cranes and forklifts can be used to stabilize motion of the machine.

SECTION 4 - EMERGENCY PROCEDURES

Rope Failure

The carriage and platform are elevated by two ropes.

Single Rope Failure

If one of the ropes fails while the platform is elevated, the other rope will allow safe descent.

Upon failure of one of the ropes, immediately lower the platform. Inform other personnel that the machine is out of service. Disassemble and clearly label the machine as being out of service. Contact your nearest Authorized JLG Service Center to arrange rope replacement.

WARNING

DO NOT ELEVATE PLATFORM WHEN IT IS ONLY SUPPORTED BY A SINGLE ROPE.

WARNING

ROPE REPLACEMENT SHALL ONLY BE CARRIED OUT BY AN AUTHORIZED JLG SERVICE CENTER.

Double Rope Failure

If both ropes fail while the platform is elevated, the emergency brake will activate automatically, locking the carriage to the mast.

In this condition the manual descent crank cannot be used to lower the platform.

Operator elevated in Platform - Platform will not lower

If the operator cannot lower the platform to the support surface call for help. The operator should then be safely removed from the platform using suitable equipment.

WARNING

DO NOT CLIMB OUT OF THE PLATFORM WHILE ELEVATED. THIS MAY AFFECT THE MACHINE'S BALANCE, CAUSING IT TO TIP OVER. ONLY EXIT THE PLATFORM VIA THE PLATFORM GATES. DO NOT ATTEMPT TO CLIMB DOWN MAST.

4.2 INCIDENT NOTIFICATION

JLG Industries, Inc. must be notified immediately of any incident involving a JLG product. Even if no injury or property damage is evident, the factory should be contacted by telephone and provided with all necessary details.

Product Safety and Reliability Department
JLG Industries, Inc.
13244 Fountainhead Plaza
Hagerstown, MD 21742
USA

In USA:
Toll Free: 877-JLG-SAFE (877-554-7233)

Outside USA:
Phone: 717-485-6591
E-mail: ProductSafety@JLG.com

Failure to notify the manufacturer of an incident involving a JLG Liftpod product within 48 hours of such an occurrence may void any warranty consideration on that particular machine.

NOTICE

FOLLOWING ANY ACCIDENT, THOROUGHLY INSPECT THE MACHINE AND TEST ALL FUNCTIONS. DO NOT ELEVATE PLATFORM UNTIL YOU ARE SURE THAT ALL DAMAGE HAS BEEN REPAIRED IF REQUIRED, AND THAT ALL CONTROLS ARE OPERATING CORRECTLY.

SECTION 4 - EMERGENCY PROCEDURES

This page intentionally left blank.

SECTION 5. GENERAL SPECIFICATIONS

5.1 Introduction

This section of the manual provides operating specifications and information necessary for proper maintenance of this machine.

5.2 Decal Installation

No.	CE	JLG Part Number
BASE		
A1	Crushing Hazard-ISO	100 107 0325
A2	Bubble Level-ISO	100 107 0327
A3	Base Crush Hazard-ISO	100 107 0439
A4	Step Plate Decal	100 107 0280
A5	General Brand	100 107 0281
A6	Contact Branding Base-CE	100 107 0449
A7	Barcode Base	100 107 0418

No.	CE	JLG Part Number
MAST/CARRIAGE		
B1	Patent	100 107 0307
B2	Manual Descent-ISO	100 107 0328
B3	Manufacturer Nameplate-ISO	100 107 0311
B4	Mast Cap Warning-ISO	100 107 0435
B5	Cowling Side Brand	100 107 0410
B6	General Brand	100 107 0281
B7	Barcode Carriage	100 107 0419
PLATFORM		
C1	Capacity-ISO	100 107 0301
C2	Tipping-ISO	100 107 0321
C3	Platform Warning Chevrons	100 107 0409
C4	Platform Latch Release-ISO	100 107 0461

SECTION 5 - GENERAL SPECIFICATIONS

No.	CE	JLG Part Number
C5	Drill Instructions-ISO	100 107 0464
C6	Electrocution-ISO	100 107 0322
C7	Read Manual-ISO	100 107 0323
C8	FS Quickstart Guide-ISO	100 107 0459
C9	Manual-CE	100 107 0465
C10	Barcode Platform	100 107 0417
C11	Contact Branding Platform-CE	100 107 0448
POWERPACK		
D1	Powerpack Socket Warning-ISO	100 107 0452
D2	E-Stop-ISO	100 107 0453
D3	Powerpack Drive Directions-ISO	100 107 0454
D4	Powerpack Battery Test-ISO	100 107 0455
D5	Powerpack Front Main Housing-ISO	100 107 0456

No.	CE	JLG Part Number
D6	Powerpack Instructions-ISO	100 107 0457
D7	Battery Charger Front-ISO	100 107 0458
D8	Battery Latch Instructions-ISO	100 107 0460
D9	Battery Warning-ISO	100 107 0462
D10	Fast Charger Back-ISO	100 107 0463
D11	Battery Charger Branding	100 107 0408
D12	General Brand	100 107 0281
D13	Barcode Powerpack	100 107 0420
D14	Barcode Charger	100 107 0421
ACCESSORY TRAY		
E1	Tool Tray-ISO	100 107 0434

Table 5-1. Decal Descriptions.

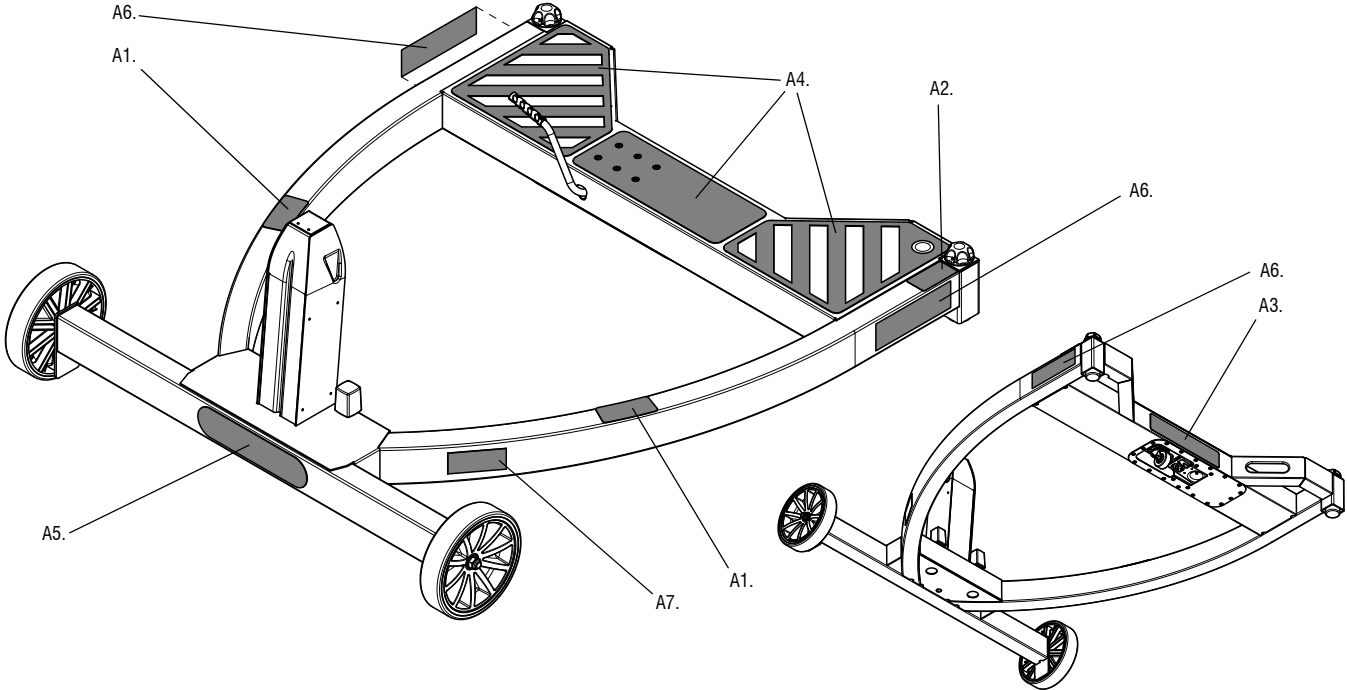

Figure 5-1. Base Decal Installation - CE

SECTION 5 - GENERAL SPECIFICATIONS

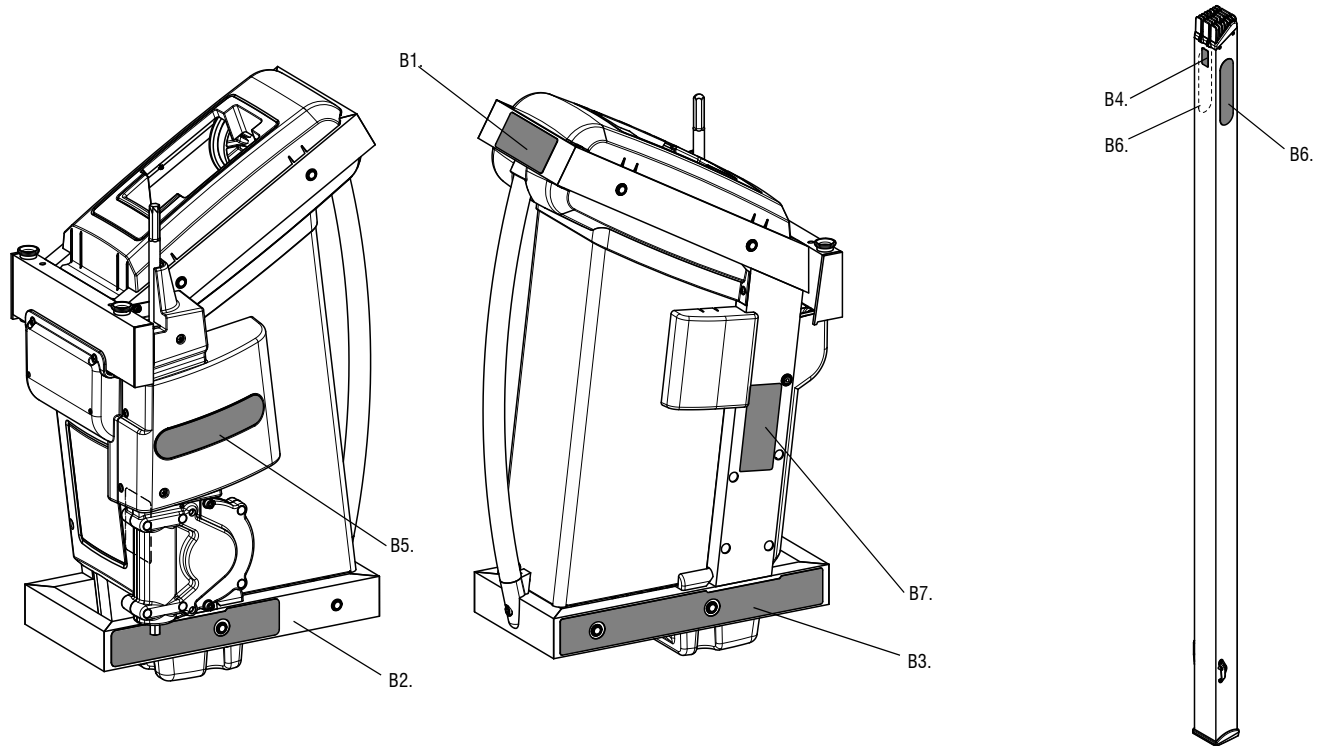

Figure 5-2. Carriage/Mast Decal Installation - CE

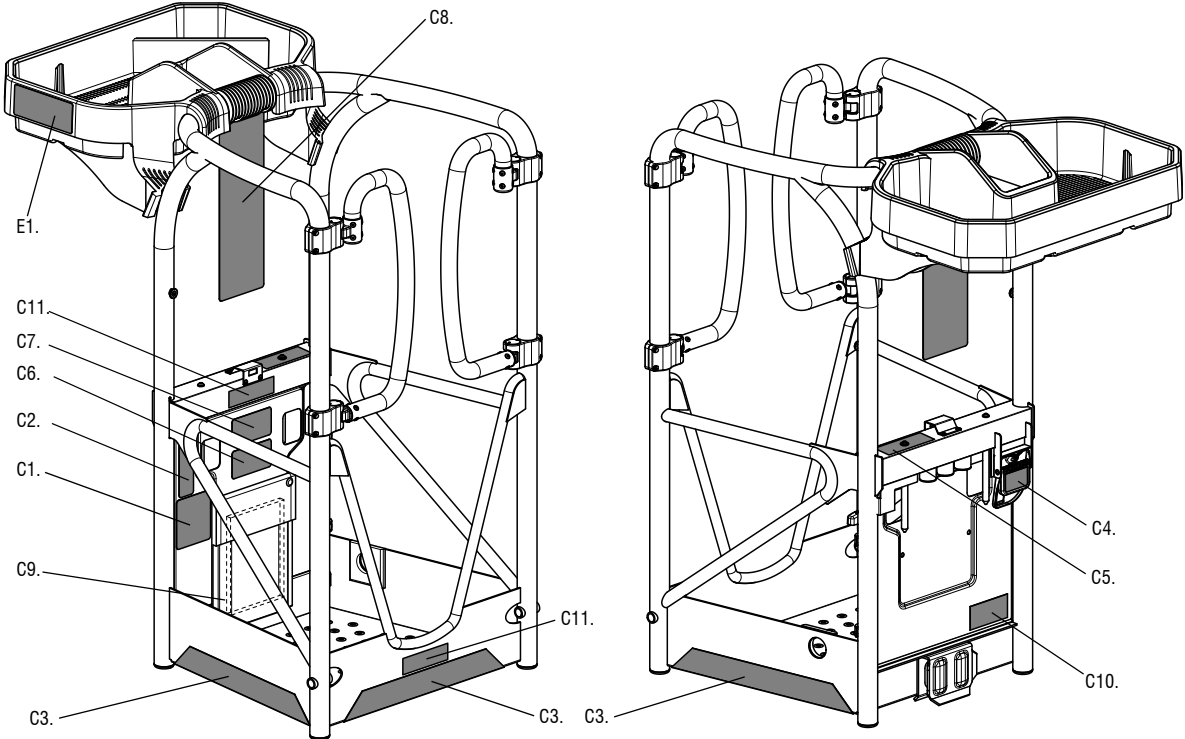

Figure 5-3. Platform Decal Installation - CE

SECTION 5 - GENERAL SPECIFICATIONS

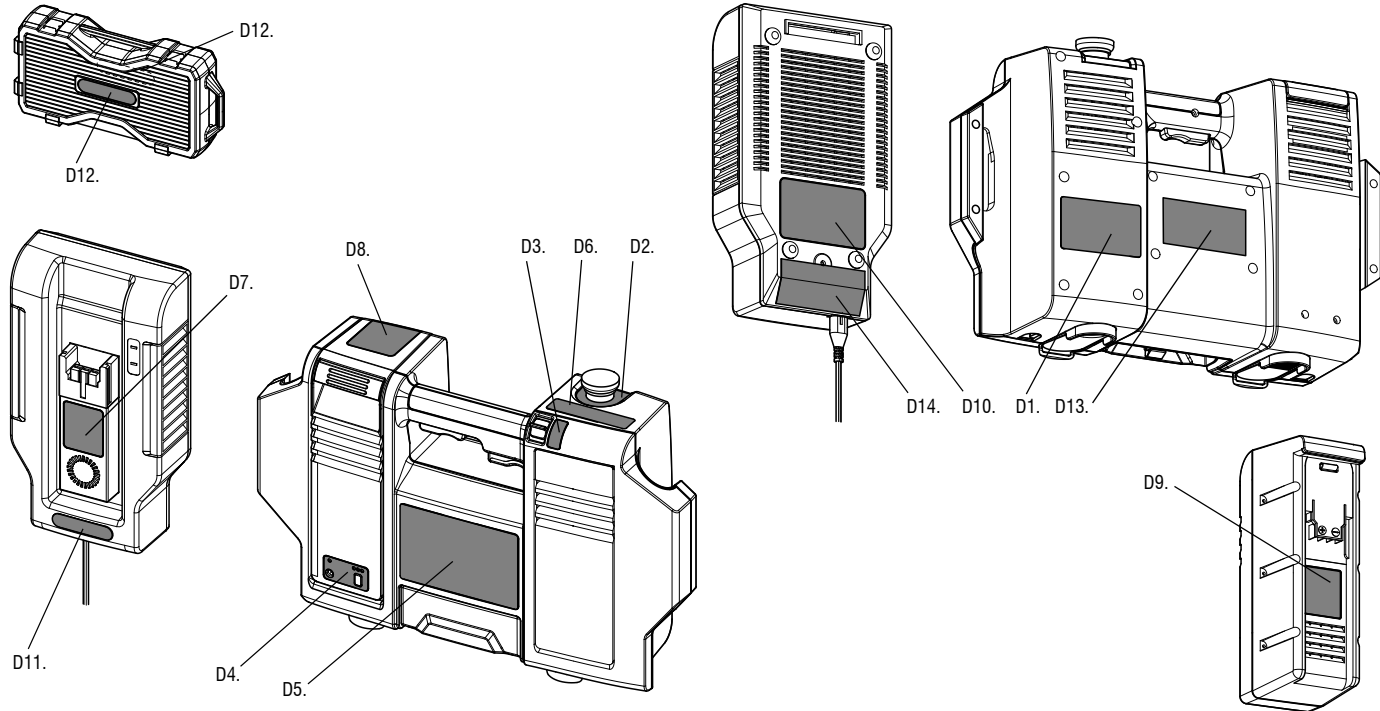

Figure 5-4. Powerpack Decal Installation - CE

5.3 General Specifications

Machine Specifications (assembled)

SPECIFICATION	FS80
Gross Machine Weight: <i>(without optional tool tray or power-pack)</i>	64.8kg (142.9 lb.)
Machine Height:	2.97m (9 ft 9 in)
Maximum Platform Floor Height:	2.32m (7 ft 7 in)
Maximum Wind Speed:	5m/sec (18 kph)
Maximum Working Height: (typical person)	4.32m (14 ft 4 in)
Machine Overall Footprint:	1,250mm x 1,040mm (4 ft 1 in x 3 ft 5 in)
Rated Horizontal Force	110N (24 lb.)

Table 5-2. Machine Specifications (assembled)

SECTION 5 - GENERAL SPECIFICATIONS

Optional Powerpack Electrical Specifications

SPECIFICATION		FS80
Batteries - Powerpack:		28.8 Volts DC
Nominal Duty Cycle at Rated Capacity:		4 cycles per 15 minutes (reduces at high and low ambient temperature)
Battery Specifications:		Battery Type
		Voltage
		Amp Hour (AH) Rating
		Weight
Battery Fast Charger:	Input:	110/240 Volts AC - 2.2A - 50/60 Hz
FC 100 107 1732	Output:	28.8 Volts DC - 2.5A - w/Auto Charge Sensing Circuit

Table 5-3. Optional Powerpack Electrical Specifications

Platform Data

SPECIFICATION	FS80
Occupants: <i>(Persons allowed in Platform)</i>	1
Platform Capacity : CE:	150kg (330 lb.)

Table 5-4. Platform Data

SECTION 5 - GENERAL SPECIFICATIONS

Machine Component Weights

SPECIFICATION	FS80
Base Frame	27.9kg (61.5 lb.)
Carriage/Mast	22.2kg (48.9 lb.)
Platform	14.7kg (32.4 lb.)
Optional Powerpack (inc Battery)	8kg (17.6 lb.)
Optional Tool Tray	3.6kg (7.9 lb.)

Table 5-5. Machine Component Weights

Serial Number Locations

For machine component identification, serial number barcode decals are affixed to the various modules. The barcodes are located as indicated in Figure 5-1. to Figure 5-4.

5.4 Supplemental Information

The following information is provided in accordance with the requirements of the European Machinery Directive 2006/42/EC and is only applicable to CE machines.

For electric powered machines, the equivalent continuous A-Weighted sound pressure level at the work platform is less than 70dB(A).

The vibration total value to which the hand-arm system is subjected does not exceed 2,5 m/s². The highest root mean square value of weighted acceleration to which the whole body is subjected does not exceed 0,5 m/s².

SECTION 6. SERVICE AND MAINTENANCE

6.1 INTRODUCTION - MAINTENANCE SAFETY PRECAUTIONS

General

This section contains the general safety precautions which must be observed during maintenance of the machine. It is important that maintenance personnel pay strict attention to these warnings and precautions to avoid possible injury to themselves or others or damage to the equipment. A maintenance program must be established by a competent person and must be followed to ensure that the machine is safe to operate.

NOTICE

JLG MAY HAVE ISSUED SAFETY BULLETINS FOR YOUR JLG PRODUCT. CONTACT JLG OR THE LOCAL AUTHORIZED JLG SERVICE CENTRE FOR INFORMATION CONCERNING SAFETY RELATED BULLETINS WHICH MAY HAVE BEEN ISSUED FOR YOUR JLG PRODUCT. ALL ITEMS REQUIRED BY THE SAFETY RELATED BULLETINS MUST BE COMPLETED ON THE AFFECTED JLG PRODUCT.

Due to continuous product improvement, JLG reserves the right to make specification changes without prior notification. Contact JLG for updated information.

WARNING

MODIFICATION OF THE MACHINE WITHOUT THE MANUFACTURERS APPROVAL IS A PROHIBITED PRACTICE AND A DIRECT SAFETY VIOLATION.

Your safety, and that of others, is the first consideration when engaging in the maintenance of equipment. Always be conscious of moving parts and pinch points. Do not allow heavy objects to rest in an unstable position. When raising a portion of the equipment, ensure that adequate support is provided.

WARNING

SINCE THE MACHINE MANUFACTURER HAS NO DIRECT CONTROL OVER THE FIELD INSPECTION AND MAINTENANCE, SAFETY IN THESE AREAS IS THE RESPONSIBILITY OF THE OWNER/OPERATOR.

SECTION 6 - SERVICE AND MAINTENANCE

Maintenance Safety

WARNING

FAILURE TO COMPLY WITH SAFETY PRECAUTIONS LISTED IN THIS SECTION COULD RESULT IN MACHINE DAMAGE, PERSONNEL INJURY OR DEATH AND IS A SAFETY VIOLATION.

- REMOVE ALL RINGS, WATCHES, AND JEWELRY WHEN PERFORMING ANY MAINTENANCE.
 - DO NOT WEAR LONG HAIR UNRESTRAINED, OR LOOSE FITTING CLOTHING AND NECKTIES WHICH ARE APT TO BECOME CAUGHT ON OR ENTANGLED IN EQUIPMENT.
 - OBSERVE AND OBEY ALL DANGER, WARNING, CAUTION AND OTHER INSTRUCTIONS ON MACHINE AND IN OPERATION, SAFETY, SERVICE & MAINTENANCE MANUAL.
 - KEEP STANDING SURFACES AND HAND HOLDS FREE OF OIL, GREASE, WATER, ETC.
 - NEVER WORK UNDER AN ELEVATED PLATFORM UNTIL PLATFORM HAS BEEN SAFELY RESTRAINED FROM ANY MOVEMENT BY BLOCKING OR OVERHEAD SLING.
 - BEFORE MAKING ADJUSTMENTS OR PERFORMING ANY OTHER MAINTENANCE, SHUT OFF ALL POWER CONTROLS.
- KEEP ALL SUPPORT EQUIPMENT AND ATTACHMENTS STOWED IN THEIR PROPER PLACE.
 - USE ONLY APPROVED, NONFLAMMABLE CLEANING SOLVENTS.

6.2 MACHINE PREPARATION, INSPECTION AND MAINTENANCE

General

This section provides the necessary information needed by those personnel that are responsible to place the machine in operation readiness and maintain its safe operating condition. For maximum service life and safe operation, ensure that all necessary inspection and maintenance has been completed before placing the machine into service.

Preparation, Inspection, and Maintenance

It is important to establish and conform to a comprehensive inspection and preventive maintenance program. Table 2-1 outlines the periodic machine inspection and maintenance recommended by JLG. Consult your national, regional, or local regulations for any further requirements. The frequency of inspection and maintenance must be increased as environment, severity and frequency of usage requires.

Pre-Start Inspection

It is the user's or operator's primary responsibility to perform a Pre-Start Inspection of the machine prior to use daily or at each change of operator. Reference Section 2 in this manual for completion procedures for the Pre-Start Inspection.

The manual must be read in its entirety and understood prior to performing the Pre-Start Inspection.

Frequent and Pre-Delivery Inspection

The Frequent Inspection and Pre-Delivery Inspection shall be performed by a competent person or a qualified mechanic.

The Frequent Inspection and Pre-Delivery Inspection procedures are performed in the same manner, but at different times. The Pre-Delivery Inspection shall be performed prior to each sale, lease, or rental delivery. The Frequent Inspection shall be accomplished for each machine in service for 3 months; out of service for a period of more than 3 months; or when purchased used. The frequency of this inspection must be increased as environment, severity and frequency of usage requires.

Reference the appropriate areas of this manual for servicing and maintenance procedures.

Annual Machine Inspection

The Annual Machine Inspection must be performed by a competent person or a qualified mechanic on an annual basis, no later than thirteen (13) months from the date of the prior Annual Machine Inspection.

Reference the Service and Maintenance Sections of this Manual and appropriate JLG inspection form for performance of this inspection.

SECTION 6 - SERVICE AND MAINTENANCE

Reference the appropriate areas of this manual for servicing and maintenance procedures.

5 Year Machine Inspection & Rope Replacement

The mast and carriage module must be inspected and the ropes replaced by an Authorized JLG Service Center when:

- The rope is worn beyond specification (see Figure 2-4.);
- A rope is tangled, damaged or broken;
- When the machine has been in service for 5 years.

NOTICE

IT IS IMPORTANT THAT JLG HAS UPDATED OWNERSHIP INFORMATION FOR EACH MACHINE COMPONENT. WHEN PERFORMING EACH ANNUAL MACHINE INSPECTION, NOTIFY JLG OF THE CURRENT MACHINE COMPONENT OWNERSHIP.

Preventive Maintenance

In conjunction with the specified inspections, maintenance shall be performed by a competent person such as a qualified JLG equipment mechanic.

6.3 PREVENTIVE MAINTENANCE AND INSPECTION SCHEDULE

The preventive maintenance and inspection checks are listed and defined in the following table. This table is divided into two basic parts, the "AREA" to be inspected and the "INTERVAL" at which the inspection is to take place. Under the "AREA" portion of the table, the various systems along with the components that make up that system are listed. The "INTERVAL" portion of the table is divided into four columns representing the various inspection time periods. The numbers listed within the interval column represent the applicable inspection code for which that component is to be checked.

The checks and services listed in this schedule are not intended to replace any local or regional regulations that may pertain to this type of equipment nor should the lists be considered as all inclusive. Variances in interval times may occur due to climate and/or conditions and depending on the location and use of the machine.

SECTION 6 - SERVICE AND MAINTENANCE

Inspection and Maintenance Codes:

- | | |
|--|---|
| <ol style="list-style-type: none"> 1. Check for proper and secure installation 2. No gouges, excessive wear, or dents showing 3. Visually inspect for excessive wear, damage, cracks, or distortion 4. Check for cracked or broken welds 5. Check area is clean and free of debris 6. Check for proper adjustment 7. Check proper operation | <ol style="list-style-type: none"> 8. Check returns to neutral or "off" position when released 9. Check for signs of leakage 10. Check for wear and/or proper routing 11. Check for proper tolerances 12. Check proper and authorized components installed 13. Verify 14. Perform 15. Replace 16. Inspect per Service and Maintenance Manual |
|--|---|

Area on Machine	Interval			
	Pre-Start Inspection	Pre-Delivery or Frequent Inspection	Annual (Yearly) Inspection	5 Year Inspection
	Prior to use each day; or at each operator change	Prior to each sale, lease or delivery; in service for 3 months or more; or purchased used	Actually no later than 13 months from the date of the prior inspection	Addition item - When rope worn or no more than 5 years from first use
Mast	1, 5,	1, 2, 5	1, 2, 3, 5	
Mast Stump	3, 5	3, 4, 5	3, 4, 5	
Rope	10, 16	10, 16	10, 16	15
Carriage	5	3, 5	1, 3, 4, 5, 7	
Gearbox	3, 9	3, 9	1, 3, 9	

SECTION 6 - SERVICE AND MAINTENANCE

Area on Machine	Pre-Start Inspection	Pre-Delivery or Frequent Inspection	Annual (Yearly) Inspection	5 Year Inspection
Manual Descent Crank	1	1, 12	1, 3, 12	
Carriage Rollers		3, 7	3, 7, 11	
Platform	1, 5	1, 5	1, 3, 4, 5, 7	
Platform Latch	1, 7	1, 3, 6, 7	1, 3, 6, 7	
Platform Gates	1, 7	1, 3, 5, 7	1, 3, 5, 7	
Lanyard Anchor		3, 4	3, 4	
Base Frame	3, 4, 5	3, 4, 5	3, 4, 5	
Adjustable Feet	1	1, 3, 7	1, 3, 7	
Bubble Level	1, 7	1, 7	1, 7	
Wheels	1, 3, 7	1, 3, 7	1, 3, 7	
Powerpack (optional)	1, 3	1, 3, 7	1, 3, 7	
Switches & Controls	1	1, 3, 7	1, 3, 7	
Speed & Safety Triggers; Battery Charge Test Button	1, 8	1, 3, 7, 8	1, 3, 7, 8	

SECTION 6 - SERVICE AND MAINTENANCE

General	Pre-Start Inspection	Pre-Delivery or Frequent Inspection	Annual (Yearly) Inspection	5 Year Inspection
Operator, Safety, Service & Maintenance Manual in Storage Pouch	13	13	13	
All Decals/Placards Installed, Secure & Legible	13	13	13	
Machine Inspection or Rope Replacement Due		16	16	14, 15
No Unauthorized Modifications or Additions		13	13	
All Relevant Safety Publications Incorporated		13	13	
General Structural Condition and Welds	13	3, 4	3, 4	
All Fasteners, Pins, Shields and Covers	13		1, 3	
Function Test of all Systems	14	14	14	
Paint and Appearance		2, 5	2, 5	
Record Inspection Date in Log Book			14	
Notify JLG of Machine Ownership		14 (delivery)	14	

Table 6-1. Preventative Maintenance & Inspection Schedule

SECTION 6 - SERVICE AND MAINTENANCE

6.4 SERVICING AND MAINTENANCE GUIDELINES

General

The following information is provided to assist you in the use and application of service and maintenance procedures contained in this chapter.

⚠ CAUTION

WHEN AN ABNORMAL CONDITION IS NOTED AND PROCEDURES CONTAINED HEREIN DO NOT SPECIFICALLY RELATE TO THE NOTED IRREGULARITY, WORK SHOULD BE STOPPED AND TECHNICALLY QUALIFIED GUIDANCE OBTAINED BEFORE WORK IS RESUMED.

Safety and Workmanship

Your safety, and that of others, is the first consideration when engaging in the maintenance of equipment. Always be conscious of moving components and pinch points. Do not allow heavy objects to rest in an unstable position. When raising a portion of the equipment, ensure that adequate support is provided.

Cleanliness

The most important single item in preserving the long service life of a machine is to keep dirt and foreign materials out of the vital

components. Precautions have been taken to safeguard against this. However, these items must be maintained on a scheduled basis in order to function properly.

⚠ WARNING

DO NOT LUBRICATE THE MACHINE. ENSURE THAT THE MAST AND EMERGENCY BRAKE ARE CLEAN AND FREE OF DEBRIS, OIL AND GREASE.

Component Disassembly and Reassembly

When disassembling or reassembling a component, complete the procedural steps in sequence. Do not partially disassemble or assemble one part, then start on another. Always recheck your work to assure that nothing has been overlooked. Do not make any adjustments, other than those recommended, without obtaining proper approval.

6.5 REPLACEMENT KITS OVERVIEW

The following details the various replacement kits that can be ordered from your Authorized JLG Service Center.

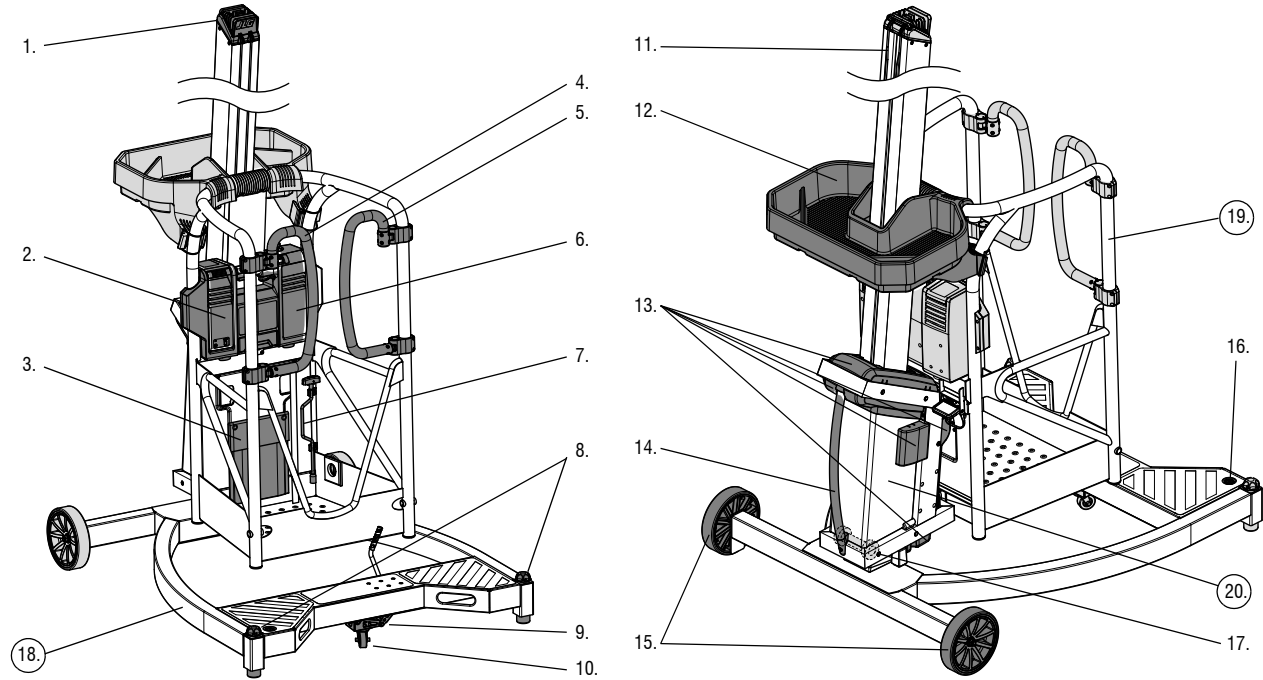

Figure 6-1. Replacement Kits

SECTION 6 - SERVICE AND MAINTENANCE

1. **Mast Cap Kit** (JLG Part No. 1001071255)
2. **Powerpack Battery** (JLG Part No. 1001071678)
3. **Manual Pouch Kit** (JLG Part No. 1001071354)
4. **Gate Assembly Kit LH** (JLG Part No. 1001071351)
5. **Gate Assembly Kit RH** (JLG Part No. 1001071352)
6. **Powerpack** (JLG Part No. 1001071677)
7. **Manual Descent Crank Kit**
(JLG Part No. 1001071353)
8. **Adjustable Foot Kit (2 feet per kit)**
(JLG Part No. 1001071562)
9. **Base Castor Mechanism Kit (JLG service only)**
(JLG Part No. 1001071566)
10. **Swivel Castor Wheel Kit** (JLG Part No. 1001071561)
11. **Rope (JLG service only)** (JLG Part No. 1001070257)
12. **Accessory Tray Kit** (JLG Part No. 1001071725)
13. **Plastic Cowlings Kit** (JLG Part No. 1001071250)
14. **Carriage Handle Kit** (JLG Part No. 1001071251)
15. **Fixed Wheel Kit (2 wheels per kit)**
(JLG Part No. 1001071560)

16. **Level Bubble Kit** (JLG Part No. 1001071563)
17. **Lower Rear Roller Kit** (JLG Part No. 1001071252)
18. **Complete Base Kit** (JLG Part No. 1001071599)
19. **Complete Platform Kit** (JLG Part No. 1001071363)
20. **Complete Mast/Carriage Kit**
(JLG Part No. 1001071197)

NOTE: *Following items not pictured.*

- **Fast Charger** (JLG Part No. 1001071732)
- **Powerpack Carry Case** (JLG Part No. 1001071705)

NOTE: *Refer to Table 5-1 and Figure 5-1. to Figure 5-4 for replacement decal positions.*

- **Decal Kit, FS80-CE** (JLG Part No. 1001071343)
- **Drill Strap Kit** (JLG Part No. 1001071361)
- **Drill Socket Kit** (JLG Part No. 1001071362)
- **Replacement Pouch Rivets** (JLG Part No. 1001071339)
- **Decal Kit, Powerpack-CE** (JLG Part No. 1001071345)

SECTION 6 - SERVICE AND MAINTENANCE

Manuals

NOTE: *Following items refer to the FS80 Operation, Safety, Service and Maintenance Manual - CE (not pictured).*

NOTE: *Not all language Manuals or Country Kits may be available. Contact your local JLG location for more information.*

- **FS80 Manual - English** (JLG Part No. 1001070465)
- **FS80 Manual - French** (JLG Part No. 1001070466)
- **FS80 Manual - German** (JLG Part No. 1001070467)
- **FS80 Manual - Dutch** (JLG Part No. 1001070468)
- **FS80 Manual - Italian** (JLG Part No. 1001070469)
- **FS80 Manual - Spanish** (JLG Part No. 1001070470)
- **FS80 Manual - Finnish** (JLG Part No. 1001070471)
- **FS80 Manual - Swedish** (JLG Part No. 1001070472)
- **FS80 Manual - Norwegian** (JLG Part No. 1001070473)
- **FS80 Manual - Danish** (JLG Part No. 1001070474)
- **FS80 Manual - Latvian** (JLG Part No. 1001070475)
- **FS80 Manual - Estonian** (JLG Part No. 1001070476)
- **FS80 Manual - Lithuanian** (JLG Part No. 1001070477)

- **FS80 Manual - Portuguese** (JLG Part No. 1001070478)
- **FS80 Manual - Greek** (JLG Part No. 1001070479)
- **FS80 Manual - Czech** (JLG Part No. 1001070480)
- **FS80 Manual - Hungarian** (JLG Part No. 1001070481)
- **FS80 Manual - Polish** (JLG Part No. 1001070482)
- **FS80 Manual - Slovakian** (JLG Part No. 1001070483)
- **FS80 Manual - Slovenian** (JLG Part No. 1001070484)
- **FS80 Manual - Maltese** (JLG Part No. 1001070485)
- **FS80 Manual - Romanian** (JLG Part No. 1001070486)
- **FS80 Manual - Bulgarian** (JLG Part No. 1001070487)
- **FS80 Manual - Russian** (JLG Part No. 1001070488)

Country Kits

NOTE: *Following items refer to the Country Kits - CE (not pictured).*

- **Country Kit - English** (JLG Part No. 1001070548)
- **Country Kit - French** (JLG Part No. 1001070549)
- **Country Kit - German** (JLG Part No. 1001070550)
- **Country Kit - Dutch** (JLG Part No. 1001070551)
- **Country Kit - Italian** (JLG Part No. 1001070552)

SECTION 6 - SERVICE AND MAINTENANCE

- **Country Kit - Spanish** (JLG Part No. 1001070553)
- **Country Kit - Finnish** (JLG Part No. 1001070554)
- **Country Kit - Swedish** (JLG Part No. 1001070555)
- **Country Kit - Norwegian** (JLG Part No. 1001070556)
- **Country Kit - Danish** (JLG Part No. 1001070557)
- **Country Kit - Latvian** (JLG Part No. 1001070558)
- **Country Kit - Estonian** (JLG Part No. 1001070559)
- **Country Kit - Lithuanian** (JLG Part No. 1001070560)
- **Country Kit - Portuguese** (JLG Part No. 1001070561)
- **Country Kit - Greek** (JLG Part No. 1001070562)
- **Country Kit - Czech** (JLG Part No. 1001070563)
- **Country Kit - Hungarian** (JLG Part No. 1001070564)
- **Country Kit - Polish** (JLG Part No. 1001070565)
- **Country Kit - Slovakian** (JLG Part No. 1001070566)
- **Country Kit - Slovenian** (JLG Part No. 1001070567)
- **Country Kit - Maltese** (JLG Part No. 1001070568)
- **Country Kit - Romanian** (JLG Part No. 1001070569)
- **Country Kit - Bulgarian** (JLG Part No. 1001070570)

- **Country Kit - Russian** (JLG Part No. 1001070570)
- **Country Kit - Australian** (JLG Part No. 1001070572)

Leads

NOTE: *Following items refer to the AC Leads (not pictured).*

- **AC Lead - 220V UK Blue** (JLG Part No. 1001071685)
- **AC Lead - 110V UK Yellow** (JLG Part No. 1001071688)
- **AC Lead - 220V Mainland Europe** (JLG Part No. 1001071693)
- **AC Lead - 220V Denmark** (JLG Part No. 1001071694)
- **AC Lead - 220V UK 3 Pin Domestic** (JLG Part No. 1001071695)
- **AC Lead - 240V Australia** (JLG Part No. 1001070573)

6.6 Decal Replacement

All decals must be mounted to the machine as specified and be clearly legible.

Please see Figure 5-1. to Figure 5-4 and refer to Table 5-1. for positions and JLG part numbers.

To replace a damaged decal, first remove it completely, without damaging the underlying surface.

Remove any remaining adhesive with a suitable solvent. Test solvent on inconspicuous area first, to ensure it does not mark or damage the underlying surface finish.

NOTICE

SURFACE DAMAGE COULD RESULT IN CORROSION AND STRUCTURAL DAMAGE.

Before applying new decal, ensure the surface is clean and dry.

Remove backing paper, apply decal along one edge then seat it gently and evenly.

If there are any air bubbles, work them gently towards the edge with a clean cloth.

Pressure sensitive adhesive reaches full strength after a several days.

SECTION 6 - SERVICE AND MAINTENANCE

6.7 Mast Rope Inspection Procedure

NOTICE

MAST ROPES ARE TO BE INSPECTED EVERY THREE MONTHS OR MORE FREQUENTLY AS DESCRIBED FOLLOWING.

The ropes should be inspected more frequently if used in a harsh environment or high duty cycle applications. Inspection should be more frequent as ropes approach the end of their useful lives. The periodic inspection shall cover the entire length of the rope.

Only the surface of the ropes require inspection, do not attempt to open the rope or remove any carriage covers. Any deterioration resulting in any loss of original strength, such as described below, shall be noted, and then a determination made if further use would constitute a hazard.

Mast ropes must be replaced after machine has been in service for five (5) years, regardless of rope condition, or sooner if conditions dictate. This must only be conducted by a Authorized JLG Service Center.

Conditions such as the following shall be sufficient reason for questioning continual use (of the rope) or increasing the frequency of inspection:

1. Rope Wear

Check rope is not frayed or damaged as per Figure 2-4. in the Daily Walk-Around Inspection Section.

2. Rope Misaligned

With carriage lowered and the platform removed, check the following:

- a. Ropes on drum should be neatly wound on adjacent grooves.

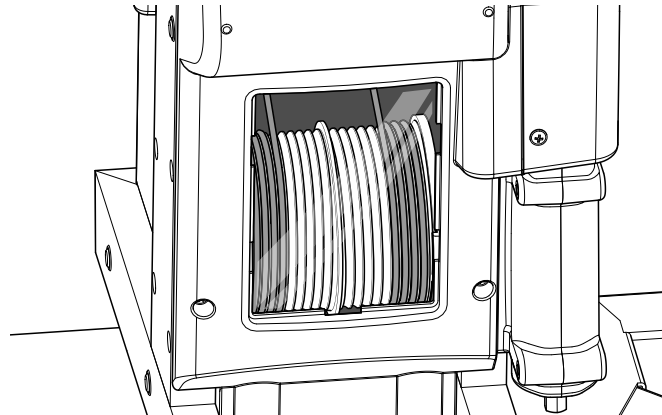
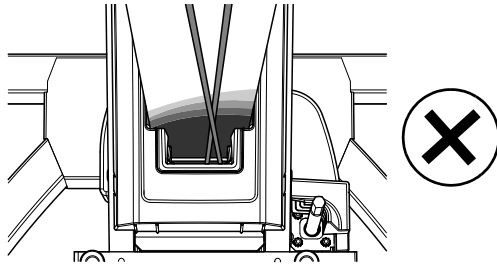
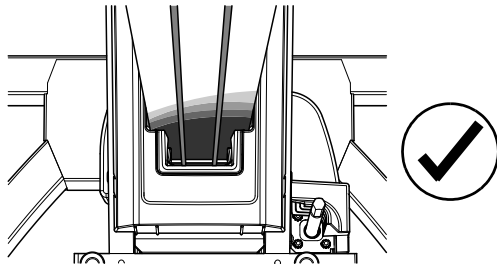

Figure 6-2. Drum view through inspection window

- b. Ropes must be parallel going into and through the carriage, looking down the mast.



Incorrect, tangled - DO NOT USE



Correct - OK to use

Figure 6-3. Rope alignment through carriage

3. Rope Loose

In normal operation the rope is always taut and should never come loose. Should the rope lose tension, say through incorrect transport or storage, it must be corrected before next use.

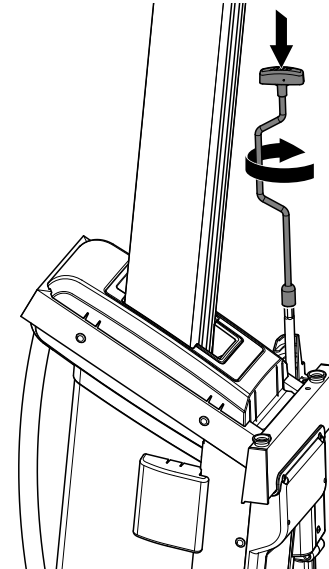

Figure 6-4. Loose rope being re-tensioned

SECTION 6 - SERVICE AND MAINTENANCE

To correct a loose rope:

1. If carriage is not within 1 m (3 ft) of the base of the mast contact JLG. Otherwise assemble the mast onto the base lifting via mast tube above carriage.
2. Check the rope is correctly on drum (Figure 6-2.).
3. Check rope is in correct location in carriage (Figure 6-3.).
4. Connect the manual descent handle directly to the carriage drive shaft (Figure 6-4.). Press down on crank and simultaneously rotate clockwise. You will hear a ratcheting noise and the drum will wind up the slack rope.
5. Re-check proper rope alignment (Figure 6-2. and Figure 6-3.). Both ropes must be tight. If ropes are not tight, contact an Authorized JLG Service Center.
6. Install platform and cordless drill (or optional power-pack). Use applicable safety precautions to enter the platform safely. Raise the platform 50mm (2 inch) to reset the emergency brake and then lower the platform to bottom of travel.
7. Perform all pre-operation checks before further use. Also, remove platform and re-check rope alignment per Figure 6-2. and Figure 6-3. after first elevation - which should be no higher than 1 m (3 ft). Ensure both ropes are tight and remain so at all times.

SECTION 7. TROUBLESHOOTING

7.1 GENERAL

This section contains troubleshooting information to be used for locating and correcting most of the operating problems which may develop in the machine. If a problem should develop which is not presented in this section or which is not corrected by listed corrective actions, technically qualified guidance should be obtained before proceeding with any maintenance.

Troubleshooting Information

The troubleshooting procedures applicable to the product are listed and defined in Table 7-1, Troubleshooting (below).

Each malfunction within an individual group or system is followed by a listing of probable causes which will enable determination of the applicable remedial action. The probable causes and the

remedial action should, where possible, be checked in the order listed in the tables.

It should be noted that there is no substitute for a thorough knowledge of the equipment and related systems.

It should be recognised that the majority of the problems arising in the machine will be centred in the power system. For this reason, every effort has been made to ensure that all likely problems in these areas are given the fullest possible treatment. In the remaining machine groups, only those problems which are symptomatic of greater problems which have more than one probable cause and remedy are included. This means that problems for which the probable cause and remedy may be immediately obvious are not listed in this section.

TROUBLE	PROBABLE CAUSE	REMEDY
Machine does not assemble properly		
	Improper alignment on assembly	Check each component and assembly alignment is correct.
	Platform not fully engaged	Check alignment and slide parts on until platform latch is properly engaged.

SECTION 7 - TROUBLESHOOTING

TROUBLE	PROBABLE CAUSE	REMEDY
Powerpack (optional) motor does not start		
	Emergency stop button is engaged (PUSHED IN) on powerpack	Disengage emergency stop button until it pops up (TURN CLOCKWISE).
	Direction selector or enable trigger or speed control trigger not activated	Select 'UP' on direction selector, then activate both the enable trigger and speed control continuously for operation.
	Battery not installed or no charge	Properly install charged battery in powerpack.
	Motor has overheated	Wait until motor cools. The temperature cutout resets itself automatically. Alternatively use manual descent procedure to lower platform (Section 4.1).
Platform does not lift up from bottom of travel - motor starts		
	Driveshaft interlock is engaged	Push cordless drill on driveshaft down firmly to disengage driveshaft safety interlock.
	(If using powerpack) Powerpack driveshaft not engaged	Check powerpack is correctly fitted to platform, latch is down and drive shaft is connected to carriage drive shaft.
	Emergency brake not released from carriage lock down latch position	Ensure a load greater than 50kg (110 lbs.) is in the platform (1 person) and lifting ropes are tight. If latch has not released, attempt to lower the loaded platform slightly then try again to lift up.

SECTION 7 - TROUBLESHOOTING

TROUBLE	PROBABLE CAUSE	REMEDY
Platform will not move when in elevated position - motor starts		
	Driveshaft interlock is engaged	Push cordless drill on driveshaft down firmly to disengage driveshaft safety interlock.
	(If using powerpack) Powerpack shaft not engaged	Check powerpack charged and in correctly fitted and is fully down and latched down.
	Drive shaft malfunction	Lower platform using manual descent procedure (see Section 4.1). Refer to Authorized JLG Service Center.
Ropes are loose (ropes must never be loose)		
	Machine was disassembled without platform being fully lowered to engage the carriage lock down latch. Carriage then moved up the mast loosening the ropes	If carriage is not within 1 m (3 ft) of the base of the mast contact Authorized JLG Service Center. Otherwise follow rope re-tensioning procedure detailed in Section 6.7, point 3. Ensure both ropes are tight and remain so at all times.
Machine does not wheel properly		
	Retractable Swivel Castor is not properly deployed	With no load in the platform or on the base - lift the castor deploy handle on front of base, adjacent to platform gate. Castor should deploy and lift front of machine off adjustable feet to allow machine to roll easily on rear wheels and front castor.
	Castor is damaged	Replace castor.



SECTION 7 - TROUBLESHOOTING

TROUBLE	PROBABLE CAUSE	REMEDY
Base will not level (DO NOT ELEVATE UNLESS BASE FIRM AND LEVEL)		
	Castor deployed	With no load in platform and people clear of adjustable feet - exert approximately 25kg pressure onto front of base. Castor should retract. Adjustable feet should then be able to be used to level the machine on slopes less than 2 degrees front to back. Do not use the machine on any side slope.
Machine rocks slightly side to side		
	Support surface is not level	Only use the machine on firm and level surfaces.
	Adjustable feet are not BOTH in contact with supporting surface	Adjust the feet so that BOTH feet are in firm contact with supporting surface AND the machine is level.
Ropes are worn or a rope is broken or machine is 5 years old or machine has been in service for 5 years since previous service		
	Damage or wear or machine is 5 years old	Deliver unit to an Authorized JLG Service Center for replacement.
Platform will not lift full rated load		
	Battery not fully charged	Charge or replace battery.
	Overload clutch is slipping	Contact Authorized JLG Service Center.

Table 7-1. Troubleshooting

SECTION 8. EC DECLARATIONS OF CONFORMITY

EC Declaration of Conformity - English

EC Declaration of Conformity						UK	
Manufacturer	JLG Industries Inc, 1 JLG Drive, McConnellsburg PA17233 USA						
Representative in EC	JLG Industries Inc, Wright Business Centre, Queenslie, Glasgow G33 4EL, Scotland						
Technical File	JLG Industries Inc, Wright Business Centre, Queenslie, Glasgow G33 4EL, Scotland						
	Contact	Alan McIntyre	Position	Manager, Engineering Support			
Product	Model	Serial Number	See Component Labels				
Liftpod by JLG	FS80	1599XXXXXXXX	Base	1677XXXXXXXX	Power Pack		
		1197XXXXXXXX	Mast/Carriage	1732XXXXXXXX	Charger		
		1363XXXXXXXX	Platform				
	FS60	1416XXXXXXXX	Mast/Carriage				
Machine, when assembled using components with serial numbers as designated above, complies with EC directives:							
2006/42/EC	Machinery	73/23/EC	Low voltage	2004/108/EC	Electromagnetic emissions		
Signature		Place	Glasgow, Scotland		Date	October 2008	
Name	Alan McIntyre	Position	Manager, Engineering Support				

SECTION 8 - EC DECLARATIONS OF CONFORMITY

This page intentionally left blank.

This page intentionally left blank.



Corporate Office
JLG Industries, Inc.
13244 Fountainhead Plaza
Hagerstown, MD 21742-2678
USA
Phone 877-2-LIFTPOD (877-254-38763)
Fax (301) 745-3713

JLG Worldwide Locations

JLG Industries (UK)
Unit 12, Southside
Bredbury Park Industrial Estate
Bredbury
Stockport
SK6 2sP
England
Phone: (44) 870 200 7700
Fax: (44) 870 200 7711

JLG Industries (Europe)
Kilmartin Place,
Tannochside Park
Uddingston G71 5PH
Scotland
Phone: (44) 1 698 811005
Fax: (44) 1 698 811055

JLG Industries (Australia)
P.O. Box 5119
11 Bolwarra Road
Port Macquarie
N.S.W. 2444
Australia
Phone: (61) 2 65 811111
Fax: (61) 2 65 810122

JLG Industries (Pty) Ltd.
Unit 1, 24 Industrial Complex
Herman Street
Meadowdale
Germiston
South Africa
Phone: (27) 11 453 1334
Fax: (27) 11 453 1342

JLG Europe B.V.
Transpolis Building
Polarisavenue 63
2132 JH HOOFDORP
The Netherlands
Phone: (31) 23 565 5665
Fax: (31) 23 557 2493

JLG Latino Americana Ltda.
Rua Eng. Carlos Stevenson,
80-Suite 71
13092-310 Campinas-SP
Brazil
Phone: (55) 19 3295 0407
Fax: (55) 19 3295 1025

JLG Polska
Ul. Krolewska
00-060 Warszawa
Poland
Phone: (48) 91 4320 245
Fax: (48) 91 4358 200

JLG Industries (Sweden)
Enkopingsvagen 150
Box 704
SE - 175 27 Jarfalla
Sweden
Phone: (46) 8 506 59500
Fax: (46) 8 506 59534

JLG Deutschland GmbH
Max Planck Strasse 21
D-27721 Ritterhude/lhlpohl
Bei Bremen
Germany
Phone: (49) 421 693 500
Fax: (49) 421 693 5035

JLG Industries (Italia)
Via Po. 22
20010 Pregnana Milanese - MI
Italy
Phone: (39) 02 9359 5210
Fax: (39) 02 9359 5845

Plataformas Elevadoras
JLG Iberica, S.L.
Trapadella, 2
Pl. Castellbisbal Sur
08755 Castellbisbal
Spain
Phone: (34) 93 77 24700
Fax: (34) 93 77 11762